

RXD-M32MD

SERVICE MANUAL

(HM-382MD)

© 2000-5/B51-5620-00 (K/K) 2335

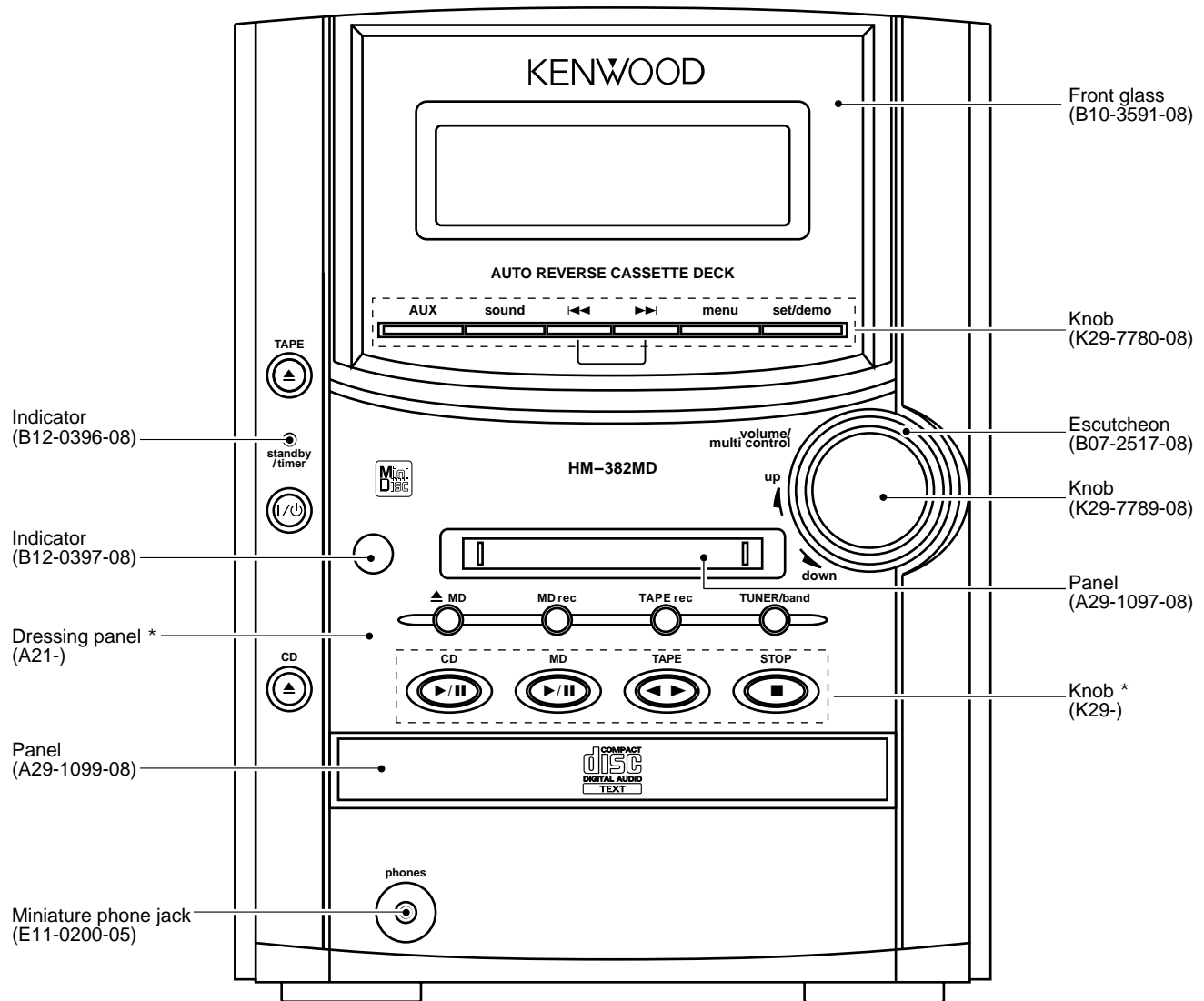

* Refer to parts list on page 46.

In compliance with Federal Regulations, following are reproductions of labels on, or inside the product relating to laser product safety.

KENWOOD-Crop. certifies this equipment conforms to DHHS Regulations No. 21 DFR 1040. 10, Chapter 1, Subchapter J.

DANGER : Laser radiation when open and interlock defeated. AVOID DIRECT EXPOSURE TO BEAM



RXD-M32MD

CONTENTS / ACCESSORIES / CAUTIONS

Contents

CONTENTS / ACCESSORIES / CAUTIONS.....	2	PC BOARD	18
EXTERNAL VIEW	3	SCHEMATIC DIAGRAM	25
DISASSEMBLY FOR REPAIR	3	EXPLODED VIEW	43
CIRCUIT DESCRIPTION	3	PARTS LIST	46
ADJUSTMENT	15	SPECIFICATIONS	Back cover

Accessories

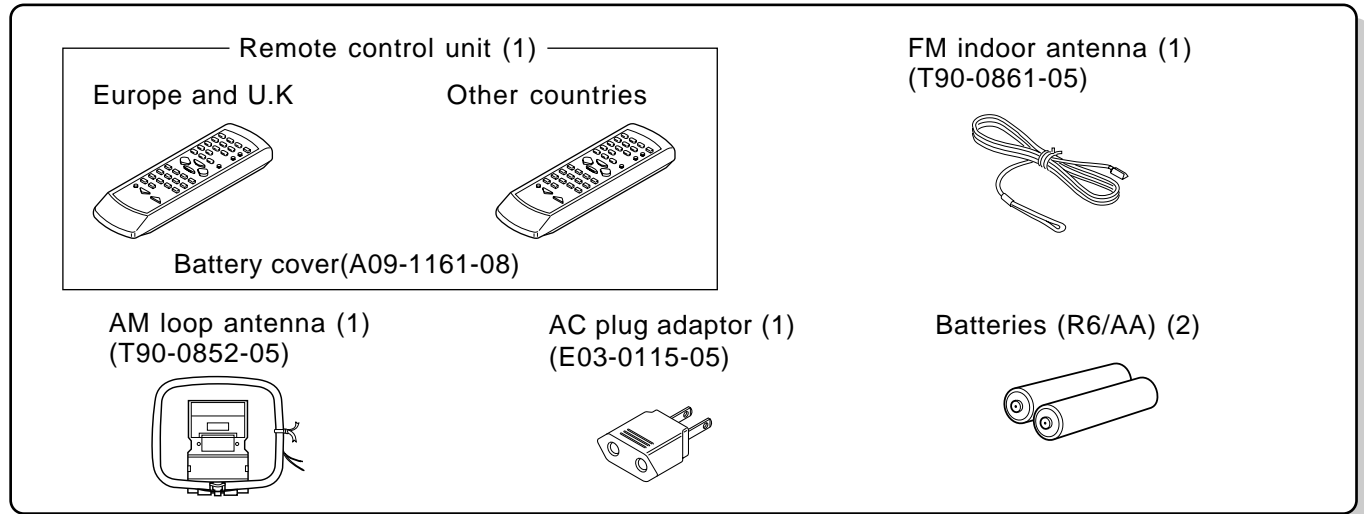

System configuration

SYSTEM	MAIN UNIT	DESTINATION	SPEAKER	COLOR
HM-382MD-L	RXD-M32MD-L	HMX(L)	LS-M32-L	BLUE
HM-382MD-S	RXD-M32MD-S	ETHM(S)	LS-M32-S	SILVER
HM-382MD-Y	RXD-M32MD-Y	M1(Y)	LS-M32-Y	YELLOW
HM-382MD-LS	RXD-M32MD-LS	HMX(LS)	LS-M32-LS	SKY • BLUE

Remocon configuration

REMOTE CONTROLLER	MODEL NAME	MODEL	DESTINATIONS	COLOR
A70-1375-08	RC-M0100	RXD-M32MD-S	M(S)	WHITE
A70-1376-08	RC-M0100E	RXD-M32MD-S/L	THE	WHITE
A70-1393-08	RC-M0100	RXD-M32MD- Y	M1(Y)	YELLOW
A70-1416-08	RC-M0100	RXD-M32MD- L	MX(L, LS)	BLUE

Cautions

Operation to reset

The microcomputer may fall into malfunction (impossibility to operate, erroneous display, etc.) when the power cord is unplugged while unit is ON or due to an external factor. In this case, execute the following procedure to reset the microcomputer and return it to normal condition.

- Please note that resetting the microcomputer clears the contents stored in and it returns to condition when it left the factory.

Unplug the power cord from the power outlet then, while holding the set/demo key depressed, plug the power cord again.

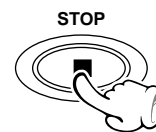
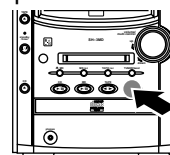

RXD-M32MD

EXTERNAL VIEW

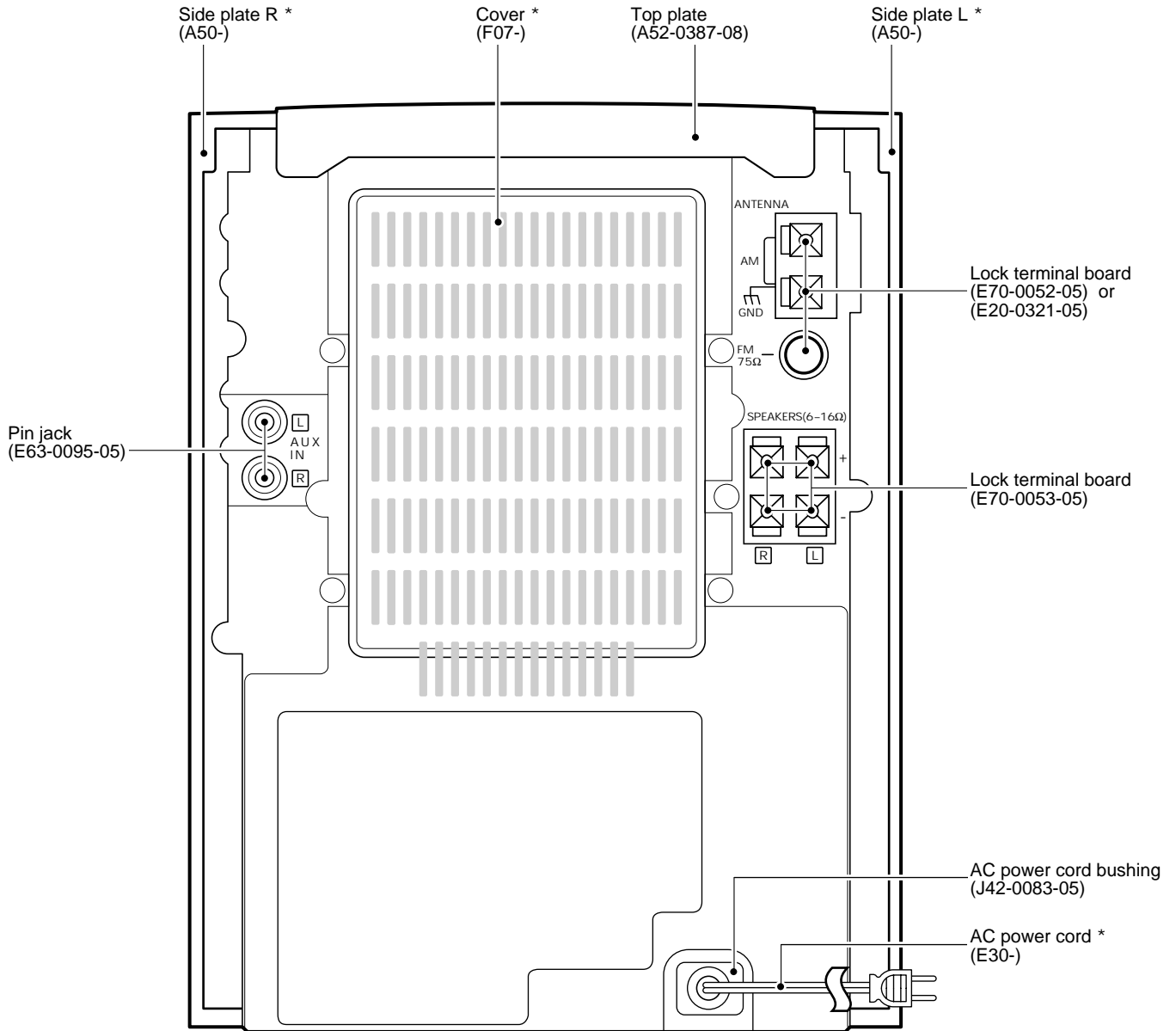

* Refer to parts list on page 46.

DISASSEMBLY FOR REPAIR

How to open the tray if not comes out.

- (1) From the bottom side of the CD mechanism, use a screw driver or the like to turn the cam slightly counterclockwise.
- (2) Pull out the tray front wards by hand when the tray comes just out.

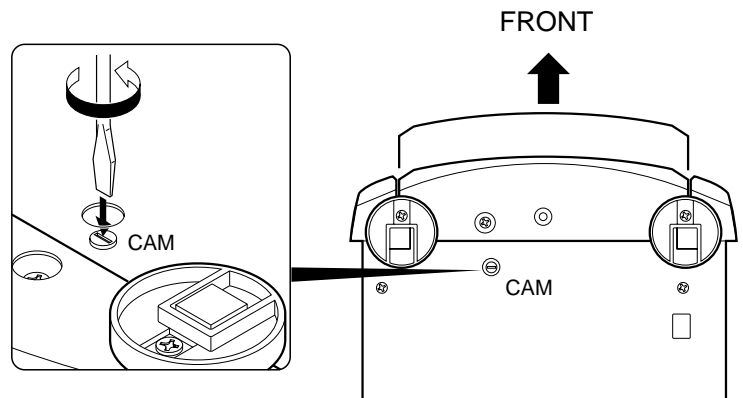

RXD-M32MD

CIRCUIT DESCRIPTION

1. Initialization

1-1 Setting of the Initial Conditions

While pressing the (STOP) key, plug the AC cord to AC wall outlet.

1-2 Initializing Operation

- A microcomputer is initialized for start when the AC power is turned on while pressing the [STOP] key.
- At that time, CD,MD and CASSETTE mechanisms are also initialized.
- During the initial conditions, the display shows "INITIALIZE" and after that it will be returned to standby conditions.

1-3 Initial Items

	ITEMS	STATE	REMARKS
AMP	POWER	OFF	
	BACK LIGHT	High	
	VOLUME	10	
	BALANCE	CENTER	
	BASS	0	
	TREBLE	0	
	EX.BASS	ON	
	LOUDNESS	OFF	
	INPUT SEL	TUNER	
	INPUT LEVEL	0	
TUNER	BAND	FM	
	LAST freq.	LOWEST FREQ.	
	LAST Preset Channel	--	
	AUTO/MONO	AUTO	
	Preset Channel	TEST FREQ.	
CLOCK TIMER	CLOCK	AM 12:00	E,T type 24H
	PROG ON (TIME)	AM 12:00	E,T type 24H
	PROG OFF (TIME)	AM 12:00	E,T type 24H
	SOURCE	TUNER	
	Preset Channel	1	
	EXE MODE	OFF	
	OTT MODE	OFF	AM 7:00
	ASP	OFF	
	SLEEP	OFF	
DECK	DIRECTION	FORWARD	
	RVS MODE	REVERSE	
	TAPE EQ	OFF	
	OPERATION MODE	STOP	
CD	PLAY MODE	TRACK	
	REPEAT	OFF	
	RANDOM	OFF	
	OPERATION MODE	STOP	
MD	PLAY MODE	TRACK	NONE
	REPEAT	OFF	NONE
	RANDOM	OFF	NONE
	OPERATION MODE	STOP	NONE

1-4 Mechanism Initialization

1-4-1 CD Mechanism

- If a mechanism error occurs, "C" is indicated on the display.

1-4-2 DECK mechanism

- When the initial condition becomes NG for the third time, decide the error.
- The error condition is displayed as "X" on the display.

1-4-3 MD mechanism

- If a mechanism error occurs, "M" is indicated on the display.
- MD disc is ejected from MD mechanism.

1-4-4 If mechanisms (CD/DECK/MD) error occur, the display is indicated as follows.

C] M] X] S] ERR]

1-4-5 TAPE door switch diagnosis

- If switches (open/close) error occur, "S" is indicated on the display.

2. Destination List of Tuner

Set	Type	BAND	Receiving Frequency Range	Channel Space	IF	RF
J	J	FM	76.0MHz~90.0MHz	100kHz	-10.7MHz	25kHz
		AM	531kHz~1629kHz	9kHz	+450kHz	9kHz
K,P	K1	FM	87.5MHz~108.0MHz	100kHz	+10.7MHz	25kHz
		AM	530kHz~1700kHz	10kHz	+450kHz	10kHz
M,Y	K2	FM	87.5MHz~108.0MHz	100kHz	+10.7MHz	25kHz
		AM	530kHz~1610kHz	10kHz	+450kHz	10kHz
	E1	FM	87.5MHz~108.0MHz	50kHz	+10.7MHz	25kHz
		AM	531kHz~1602kHz	9kHz	+450kHz	9kHz
X	E1	FM	87.5MHz~108.0MHz	50kHz	+10.7MHz	25kHz
		AM	531kHz~1602kHz	9kHz	+450kHz	9kHz
E,T	RDS	FM	87.5MHz~108.0MHz	50kHz	+10.7MHz	25kHz
		AM	531kHz~1602kHz	9kHz	+450kHz	9kHz

2-1 Discrimination Port for Destination

TYPE	R292 [Ω]	VOLTAGE [V]
J	910k	4.505
K	220k	3.438
M1	100k	2.500
X	47k	1.600
E,T	12k	0.536

AVdd = 5.0 [v]

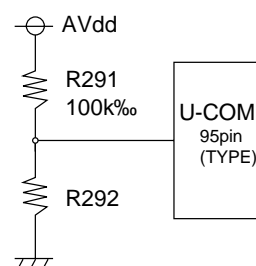

3. Test Mode

3-1 Setting of the Test Mode

AUX MODE	AUX Key+AC-ON
TUNER MODE	TUNER (BAND) Key+AC-ON
TAPE MODE	TAPE PLAY Key+AC-ON
CD MODE	CD PLAY Key+AC-ON
MD UNIT MODE	MD PLAY key + AC ON (MD version only)
MD MECHA. MODE	MD REC key +AC-ON
SUB CLOCK OSC DIAGNOSIS	TAPE REC Key+AC-ON The oscillation diagnosis(existence of oscillation and measurement of period) of a sub clock is performed before the test mode is entered. If the diagnosis result is OK, the system enters the test mode. If the diagnosis result is NG, the oscillation of the sub clock is diagnosed again. If the result is OK, the system enters the test mode. If the diagnosis result is continuously NG 5 times,the system stops with "ERR1" and "ERR2" displayed.

CIRCUIT DESCRIPTION

3-2 Cancel of the test mode

By turning the power off, the system is initialized and the test mode is canceled.

3-3 Contents of the Test Mode

3-3-1 Tuner Test mode

KEY	DISPLAY	OPERATION
STOP	Normal indication	P --→ P10 → P20 → P30 → P40 →
MENU	Normal indication	AUTO · STEREO ↑ MANUAL · MONO ↓
MD REC TAPE REC	Normal indication	TUNING DOWN TUNING UP
SKIP DOWN SKIP UP	Normal indication	P. ch DOWN P. ch UP

3-3-2 Aux Test Mode

KEY	DISPLAY	OPERATION
SET/demo	Tone] MAX]]] Tone] MAX]]] Tone] CENTER	CENTER → MAX → MIN →
SKIP UP	Normal indication	EX. BASS ON → LOUDNESS ON → SOUND MODE OFF

3-3-3 Deck Test Mode

KEY	DISPLAY	OPERATION
TAPE REC	Normal display	If the REC/ARM key is pressed, the system record for 4 seconds. Then, it rewinds to the REC starting position and plays back automatically. If the REC/ARM key is pressed, during the 4 seconds REC operation, the system records further for 4 seconds, then returns to the starting position of the first 4 seconds REC operation and plays back.

3-3-4 CD Test Mode

- The CD tray is opened automatically when the test mode is entered.

KEY	DISPLAY	OPERATION
CD-PLAY/PAUSE (Change the mode 05 and 03 alternately by the stop key.)	05 * * : * * (* * : * *)	Tracking-servo on.
	03 --:--	Tracking-servo off.
CD STOP (Cyclically changed in the stop mode only.)	01 --:--	STOP
	07 * * / * * 08 * * / * * 09 * * / * * 10 * * / * *	Adjustment value/mean value TB value FB value TG value FG value FE value RF value TE value VC value
MENU	HI-SPEED NOR-SPEED	CD double speed operation CD normal speed operation
SKIP UP	Ex.01~02	CD track no. up.
TAPE REC		CD FF search. The pickup travels outward in the stop mode.
SKIP DOWN	Ex.02~01	CD track no. down.
MD REC		CD FB search. The pickup travels inward in the stop mode.

4. MD Test Mode

4-1 MD Unit Mode

Key	Display	Description
STOP	001—:—	Stop the MD operation.
SKIP UP	EX : 01-02	MD's track up operation.
SKIP DOWN	EX : 02-01	MD's track down operation.
SET/demo	ALL ERASE	Stop the MD operation. Start operation of all erase if disc is recordable.

RXD-M32MD

CIRCUIT DESCRIPTION

4-2 MD SECTION

1. Preparation for Adjustment

You have to carry out the following test mode items if replace MD mechanism, pickup, head and pc board.

1-1 Procedure

1. Short-circuit #4(vss) and #7(wp) of IC1402(EEPROM).
2. Set the unit to test mode and carry out the every adjustment in test mode.
3. Stop the test mode by pressing the STOP key for 3 secs
4. Remove the short circuit of IC1402. Carry out reset start.

Repair(replace)	Temperature Standard Set	EEPROM set value check	Auto pre adj	Auto adj	Auto Fab adj	*EEPROM data write	** Operation check	
	TEMP	EEPROM_SET	AUTO_YOBI	AUTO_ADJ	AUTO_FAB	CANCEL TEST MODE	TEST-PLAY	TEST-REC
pickup	-	1	2	3	4	5	6	7
recording head	-	-	-	-	-	-	-	1
mechanism	-	1	2	3	4	5	6	7
pcb parts	1	2	3	4	5	6	7	8
MD microprocessor	-	1	-	-	-	2	3	4
MD LSI	-	-	1	2	3	4	5	6
RF IC	1	2	3	4	5	6	7	8
EEPROM	1	2	3	4	5	6	7	8

note: figures order of steps. - = no need.

* Result of EEPROM

- OK_EEPROM Write the data of setting values and AUTO-pre adjustment perfectly.
- WR_EEPROM Write the data of setting values perfectly however not write AUTO pre-adjustment.
Carry out AUTO-pre adjustment and write data to EEPROM.
- NG_EEPROM Not write the data of setting values.
Check the connection of MD microprocessor and EEPROM.

** Carry out the TEST-PLAY , TEST-REC and C1 error in test mode after AUTO_ADJ and AUTO_FAB.

1-2 Test disc

	Type	Test disc
1	High reflection disc	TGYS1 (SONY)
2	Low reflection disc	Recording minidisc
3	—————	Head Adjusting transparent

2. Test Mode

1. Holding down the MD rec button and turn the power on. (State ①)
2. To enter the test mode stop state(State ②), press the STOP button.
3. Load the playback disc 1(high reflection disc) or recording disc 2(low reflection disc).

- ① MD TEST
↓ (Press STOP key)
- ② tsm ○○○○e○○ ---- TEST MODE STOP STATE ○○represents version of MD microcomputer
↓ (MD DISC LOAD IN)
- ③ LOADING
↓
- ④ AUT YOBI (When the STOP button is pressed in the ④ state, the indication ② state is restored.
To restore ④ state again, press the SKIP DOWN key once.

Entering the specific mode

Whenever the SKIP DOWN(◀) button is pressed, the mode is changed.

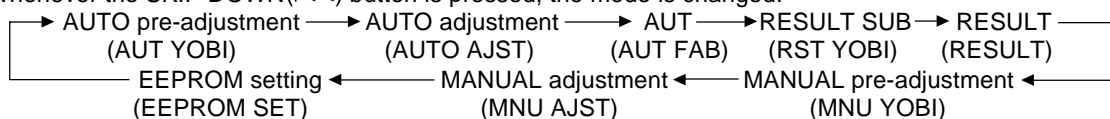

CIRCUIT DESCRIPTION

• Canceling the test mode

When the POWER button is pressed, the test mode is canceled, and the POWER OFF state is set.

• Test Mode

1. AUTO pre-adjustment mode	<ul style="list-style-type: none"> Automatic pre-adjustment is performed. (After adjustment the grating adjustment mode is set.) The adjustment value is output with the aid of system controller interface.
2. AUTO adjustment mode	<ul style="list-style-type: none"> Automatic adjustment is performed. The adjustment value is output with the aid of system controller interface. Continuous playback is performed. (Error rate indication, jump test)
3. AUTO FOCUS BIAS adjustment	<ul style="list-style-type: none"> Focus bias adjustment is performed automatically.
4. RESULT sub-mode	<ul style="list-style-type: none"> The measurement value, set value and calculated value are indicated. The set value is changed manually (in servo OFF state).
5. RESULT mode (final adjustment)	<ul style="list-style-type: none"> The set value (after calculation) is indicated. The set value is changed manually (in servo OFF state).
6. MANUAL pre-adjustment mode	<ul style="list-style-type: none"> RF side manual adjustment is performed. Focus and tracking signal ATT manual adjustment is performed. Focus and tracking signal offset setting is performed.
7. MANUAL adjustment mode	<ul style="list-style-type: none"> Focus and tracking signal ATT manual adjustment is performed.
8. EEPROM setting mode	<ul style="list-style-type: none"> EEPROM setting
9. TEST-PLAY mode	<ul style="list-style-type: none"> Continuous playback from the specified address is performed. C1 error rate measurement.
10. TEST-REC mode	<ul style="list-style-type: none"> Continuous recording from the specified address is performed. Change of record laser output (servo gain is also changed according to laser output)
11. EJECT mode	<ul style="list-style-type: none"> TEMP setting (of EEPROM setting)

1. AUTO pre-adjustment mode (Low reflection disc only)

Step No.	Setting Method	Remarks	Display
Step 1	Test mode STOP state		[t s m○○○○ e ○○]
Step 2	Press once the SKIP DOWN(⏮) button.	AUTO pre-adjustment menu	[_ AUT_YOBI_ _ _]
Step 3	Press once the MD PLAY button.	The slide moves to the innermost periphery, and automatic pre-adjustment is started. <ul style="list-style-type: none"> During automatic adjustment *** changes as follows. HAo→RFg→SAg→SBg→PTG→PCH→GTG→GCH→RCG→SEG→RFG→SAG→HAO→HEO→TCO→LAO If adjustment is OK, Step 4. If adjustment is NG, Step 5.	[*** : _ _ _ _ _]
	End of adjustment		
Step 4	Grating adjustment, adjustment value output Press once the MD STOP button.	STEP 2	[_ C O M P L E T E _]
Step 5	Adjustment value output Press once the MD STOP button.	STEP 2 AUTO pre-adjustment menu	[AUT YOBI]

• *** : Adjustment name, □□□□ : Address

2. AUTO adjustment mode

Step No.	Setting Method	Remarks	Display
Step 1	Test mode STOP state		[t s m○○○○ e ○○]
Step 2	Press the SKIP DOWN(⏮) button two times.	AUTO adjustment menu	[A U T O _ A J S T _]
Step 3	Press once the MD PLAY button.	The slide moves to the innermost periphery, and automatic adjustment is started. <ul style="list-style-type: none"> In case of high reflection disc *** changes as follows. PEG→HAG In case of low reflection disc *** changes as follows. PEG→LAG→GCG→GEG→LAG If adjustment is OK, Step 4. If adjustment is NG, Step 7.	[*** : _ _ _ _ _]
	End of adjustment		[C O M P L E T E]
Step 4	Adjustment value output Press the MD PLAY button. Press the MD STOP button.	STEP 5 STEP 2	
Step 5	Continuous playback (groove section)		[a□□□□c○○○○]
Step 6	Press the MD STOP button.	STEP 2 AUTO adjustment menu	
Step 7	Adjustment value output Press the MD STOP button.	STEP 2 AUTO adjustment menu	[C a n ' t _ A D J .]

• *** : Adjustment name, ○○ : Measurement value, □□□□ : Address

RXD-M32MD

CIRCUIT DESCRIPTION

3. AUTO FAB adjusting mode

Step No.	Setting Method	Remarks	Display
Step 1	Test mode STOP state		[tsm○○○○e○○]
Step 2	Press the SKIP DOWN(◀◀) button three times	AUTO FAB adjustment menu	[_AUT_FAB_]
Step 3	Press the MD PLAY button 1 time	End of automatic adj. → step 4 High reflection disc → step 5	[FAB□□_△△△△]
Step 4	Press the MD STOP button	AUTO FAB adjustment menu, step 2	[●●_△△△△○○]
Step 5		Message output for 1 sec. → AUTO FAB. Adjustment menu(high reflection disc)	「PB_DISC_」

- ○○○○: measurement value □□: FAB value in measurement, △△△△ C1 error value in measurement, ●●: FAB value
- If the STOP button is pressed twice while the AUTO FAB adjustment is displayed, the state is change to the TEST mode STOP state.

4. RESULT sub-mode

Step No.	Setting Method	Remarks	Display
Step 1	Test mode STOP state		[t s m○○○○ e ○○]
Step 2	Press the SKIP DOWN(◀◀) button 4 times.	RESULT sub-menu	[_ R S T _ Y O B I _]
Step 3	Press once the MD PLAY button.	Indication of measurement value	[R F G : _ _ _ _ ●]
Step 4	Press once the SKIP DOWN(◀◀) button.	Indication of measurement value	[R C G : _ _ _ _ ●]
Step 5	Press once the SKIP DOWN(◀◀) button.	Indication of measurement value	[P T G : _ _ _ _ ●]
Step 6	Press once the SKIP DOWN(◀◀) button.	Indication of measurement value	[G T G : _ _ _ _ ●]
Step 7	Press once the SKIP DOWN(◀◀) button.	Indication of measurement value	[P C H : _ _ _ _ ●●]
Step 8	Press once the SKIP DOWN(◀◀) button.	Indication of measurement value	[G C H : _ _ _ _ ●●]
Step 9	Press once the SKIP DOWN(◀◀) button.	Indication of measurement value	[S A G : _ _ _ ●●●]
Step 10	Press once the SKIP DOWN(◀◀) button.	Indication of measurement value	[S B G : _ _ _ ●●●]
Step 11	Press once the SKIP DOWN(◀◀) button.	Indication of measurement value	[S E G : _ _ _ ●●●]
Step 12	Press once the SKIP DOWN(◀◀) button.	Indication of measurement value	[S F G : _ _ _ ●●●]
Step 13	Press once the SKIP DOWN(◀◀) button.	Indication of measurement value	[H A O : ○○○ _ _]
Step 14	Press once the SKIP DOWN(◀◀) button.	Indication of measurement value	[H B O : ○○○ _ _]
Step 15	Press once the SKIP DOWN(◀◀) button.	Indication of measurement value	[H E O : ○○○ _ _]
Step 16	Press once the SKIP DOWN(◀◀) button.	Indication of measurement value	[H F O : ○○○ _ _]
Step 17	Press once the SKIP DOWN(◀◀) button.	Indication of measurement value	[L A O : ○○○ _ _]
Step 18	Press once the SKIP DOWN(◀◀) button.	Indication of measurement value	[L B O : ○○○ _ _]
Step 19	Press once the SKIP DOWN(◀◀) button.	Indication of measurement value	[L E O : ○○○ _ _]
Step 20	Press once the SKIP DOWN(◀◀) button.	Indication of measurement value	[L F O : ○○○ _ _]
Step 21	Press once the SKIP DOWN(◀◀) button.	Indication of measurement value	[T C O : _ ○○ _ _]
Step 22	Press once the SKIP DOWN(◀◀) button.	Indication of adjustment error sequence No.	[Y O B : _ □□ _ _]
Step 23	Press once the SKIP DOWN(◀◀) button.	Indication of adjustment status	[D I F : _ □□ _ _]
Step 24	Press once the SKIP DOWN(◀◀) button.	Indication of pre-adjustment not completed (00)/completed (4B)	[A D J : _ □□ _ _]
Step 25	Press once the MD STOP button.	RESULT sub-menu state	[_ R S T _ Y O B I _]

- ○○ : Measurement value, ●● : Adjustment value, □□ : Other various informations
- When the (▶▶)button in remote controller is pressed while the setting is displayed, the setting increases, and a new setting is stored in RAM.
- When the (◀◀)button in remote controller is pressed while the setting is displayed, the setting increases, and a new setting is stored in RAM.
- When the (▶▶) or (◀◀)button in remote controller is pressed continuously, steps is change by 100ms period.

CIRCUIT DESCRIPTION

5. RESULT mode (final adjustment)

Step No.	Setting Method	Remarks	Display
Step 1	Test mode STOP state		[t s m○○○○ e○○]
Step 2	Press the SKIP DOWN(◀◀) button 5 times.	RESULT menu	[_ R S T U L T _ _ _]
Step 3	Press once the MD PLAY button.	Indication of set value	[H A G : _ _ _ ●●●]
Step 4	Press once the SKIP DOWN(◀◀) button.	Indication of set value	[H B G : _ _ _ ●●●]
Step 5	Press once the SKIP DOWN(◀◀) button.	Indication of set value	[L A G : _ _ _ ●●●]
Step 6	Press once the SKIP DOWN(◀◀) button.	Indication of set value	[L B G : _ _ _ ●●●]
Step 7	Press once the SKIP DOWN(◀◀) button.	Indication of set value	[P E G : _ _ _ ●●●]
Step 8	Press once the SKIP DOWN(◀◀) button.	Indication of set value	[P F G : _ _ _ ●●●]
Step 9	Press once the SKIP DOWN(◀◀) button.	Indication of set value	[G E G : _ _ _ ●●●]
Step 10	Press once the SKIP DOWN(◀◀) button.	Indication of set value	[G F G : _ _ _ ●●●]
Step 11	Press once the SKIP DOWN(◀◀) button.	Indication of set value	[G C G : _ _ _ ●●]
Step 12	Press once the MD STOP button.	RESULT menu state	[_ R E S U L T _ _ _]

- : Measurement value
- When the (▶▶)button in remote controller is pressed while the setting is displayed, the setting increases, and a new setting is stored in RAM.
- When the (◀◀)button in remote controller is pressed while the setting is displayed, the setting decreases, and a new setting is stored in RAM.
- When the (▶▶) or (◀◀)button in remote controller is pressed continuously, steps is change by 100ms period.

6. MANUAL auxiliary adjustment mode (only low reflection disc)

Step No.	Setting Method	Remarks	Display
Step 1	Test mode STOP state		[t s m○○○○ e○○]
Step 2	Press the SKIP DOWN(◀◀) button 6 times.	MANUAL auxiliary adjustment mode	[_ M N U _ Y O B I _]
Step 3	Press once the MD PLAY button.	Initial setting → Temperature measuring mode	[T M P : _ ΔΔ _ _ _]
Step 4	Press once the SKIP DOWN(◀◀) button.	Offset "0" setting → A signal offset tentative measurement	[H A o : ΔΔΔ _ _ _]
Step 5	Press once the SKIP DOWN(◀◀) button.	B signal offset tentative measurement	[H B o : ΔΔΔ _ _ _]
Step 6	Press once the SKIP DOWN(◀◀) button.	E signal offset tentative measurement	[H E o : ΔΔΔ _ _ _]
Step 7	Press once the SKIP DOWN(◀◀) button.	F signal offset tentative measurement	[H F o : ΔΔΔ _ _ _]
Step 8	Press once the SKIP DOWN(◀◀) button.	Offset tentative measurement → Laser ON	[L O N : _ _ _ _ _]
Step 9	Press once the SKIP DOWN(◀◀) button.	Innermost periphery move → RF side FG rough adjustment	[R F g : ΔΔΔ _ _ ●]
Step 10	Press once the SKIP DOWN(◀◀) button.	Focus ATT (A signal) tentative setting	[S A g : ΔΔΔ○○○]
Step 11	Press once the SKIP DOWN(◀◀) button.	Focus ATT (B signal) tentative setting	[S B g : ΔΔΔ○○○]
Step 12	Press once the SKIP DOWN(◀◀) button.	RF side pit section TG adjustment	[P T G : ΔΔΔ _ _ ●]
Step 13	Press once the SKIP DOWN(◀◀) button.	Pit section COUT level setting	[P C H : ΔΔΔ _ ○○]
Step 14	Press once the SKIP DOWN(◀◀) button.	Outer periphery move → RF side groove TG adjustment	[G T G : ΔΔΔ _ _ ●]
Step 15	Press once the SKIP DOWN(◀◀) button.	Groove section COUT level setting	[G C H : ΔΔΔ _ ○○]
Step 16	Press once the SKIP DOWN(◀◀) button.	RF side TCRS adjustment	[R C G : ΔΔΔ _ _ ●]
Step 17	Press once the SKIP DOWN(◀◀) button.	Tracking ATT (E signal) setting	[S E G : ΔΔΔ○○○]
Step 18	Press once the SKIP DOWN(◀◀) button.	Tracking ATT (F signal) setting	[S F G : ΔΔΔ○○○]
Step 19	Press once the SKIP DOWN(◀◀) button.	Indication of tracking EFMIO measurement	[g M I : ΔΔΔ _ _ _]
Step 20	Press once the SKIP DOWN(◀◀) button.	RF side pit section FG adjustment	[R F g : ΔΔΔ _ _ ●]
Step 21	Press once the SKIP DOWN(◀◀) button.	Focus ATT (A signal) setting	[S A G : ΔΔΔ○○○]
Step 22	Press once the SKIP DOWN(◀◀) button.	Focus ATT (B signal) setting	[S B G : ΔΔΔ○○○]
Step 23	Press once the SKIP DOWN(◀◀) button.	Offset "0" setting → A signal offset measurement	[H A O : ΔΔΔ _ _ _]
Step 24	Press once the SKIP DOWN(◀◀) button.	B signal offset measurement	[H B O : ΔΔΔ _ _ _]
Step 25	Press once the SKIP DOWN(◀◀) button.	E signal offset measurement	[H E O : ΔΔΔ _ _ _]
Step 26	Press once the SKIP DOWN(◀◀) button.	F signal offset measurement	[H F O : ΔΔΔ _ _ _]
Step 27	Press once the SKIP DOWN(◀◀) button.	TCRS signal offset measurement	[T C O : ΔΔΔ _ _ _]
Step 28	Press once the SKIP DOWN(◀◀) button.	A signal offset measurement	[L A O : ΔΔΔ _ _ _]
Step 29	Press once the SKIP DOWN(◀◀) button.	B signal offset measurement	[L B O : ΔΔΔ _ _ _]
Step 30	Press once the SKIP DOWN(◀◀) button.	E signal offset measurement	[L E O : ΔΔΔ _ _ _]
Step 31	Press once the SKIP DOWN(◀◀) button.	F signal offset measurement	[L F O : ΔΔΔ _ _ _]
Step 32	Press once the MD STOP button.	MNU YOBI state	[_ M N U _ Y O B I _]

- △△△ : Measurement value, ● : Set value, ○○○ : Account value

RXD-M32MD

CIRCUIT DESCRIPTION

- When the (▶▶) button in remote controller is pressed while the setting is displayed, the setting increases, and a new setting is stored in RAM.
- When the (◀◀) button in remote controller is pressed while the setting is displayed, the setting increases, and a new setting is stored in RAM.
- When the (▶▶) or (◀◀) button in remote controller is pressed continuously, steps is change by 100ms period. If the measurement value is within the OK range, "※" appears on the 8th character.

7. MANUAL adjustment mode

High reflection disc

Step No.	Setting Method	Remarks	Display
Step 1	Test mode STOP state		[t s m 0 0 0 0 e 0 0]
Step 2	Press the SKIP DOWN(◀◀) button 7 times.	MANUAL adjustment menu	[_ M N U _ A J S T _]
Step 3	Press once the MD PLAY button.	Initial setting → Temperature measuring mode	[T M P : _ Δ Δ _ _ _]
Step 4	Press once the SKIP DOWN(◀◀) button.	Laser ON	[L O N : _ _ _ _ _]
Step 5	Press once the SKIP DOWN(◀◀) button.	Innermost periphery move → Tracking ATT (E signal) setting	[P E G : Δ Δ Δ 0 0 0]
Step 6	Press once the SKIP DOWN(◀◀) button.	Tracking ATT (F signal) setting	[P F G : Δ Δ Δ 0 0 0]
Step 7	Press once the SKIP DOWN(◀◀) button.	Indication of tracking EFMIO measurement	[P M I : Δ Δ Δ _ _ _]
Step 8	Press once the SKIP DOWN(◀◀) button.	Focus ATT (A signal) setting	[H A G : Δ Δ Δ 0 0 0]
Step 9	Press once the SKIP DOWN(◀◀) button.	Focus ATT (B signal) setting	[H B G : Δ Δ Δ 0 0 0]

- If the MD STOP button is pressed twice while the MANUAL adjustment menu is displayed, the state is changed to the TEST mode STOP state.

Low reflection disc

Step No.	Setting Method	Remarks	Display
Step 1	Test mode STOP state		[t s m 0 0 0 0 e 0 0]
Step 2	Press the SKIP DOWN(◀◀) button 7 times.	MANUAL adjustment menu	[_ M N U _ A J S T _]
Step 3	Press once the MD PLAY button.	Initial setting → Temperature measuring mode	[T M P : _ Δ Δ _ _ _]
Step 4	Press once the SKIP DOWN(◀◀) button.	Laser ON	[L O N : _ _ _ _ _]
Step 5	Press once the SKIP DOWN(◀◀) button.	Innermost periphery move → Tracking ATT (E signal) setting	[P E G : Δ Δ Δ 0 0 0]
Step 6	Press once the SKIP DOWN(◀◀) button.	Tracking ATT (F signal) setting	[P F G : Δ Δ Δ 0 0 0]
Step 7	Press once the SKIP DOWN(◀◀) button.	Indication of tracking EFMIO measurement (pit section)	[P M I : Δ Δ Δ _ _ _]
Step 8	Press once the SKIP DOWN(◀◀) button.	Focus ATT (A signal) setting	[L A g : Δ Δ Δ 0 0 0]
Step 9	Press once the SKIP DOWN(◀◀) button.	Focus ATT (B signal) setting	[L B g : Δ Δ Δ 0 0 0]
Step 10	Press once the SKIP DOWN(◀◀) button.	Outside periphery move → Track cross setting	[G C G : Δ Δ Δ 0 0 0]
Step 11	Press once the SKIP DOWN(◀◀) button.	Tracking ATT (E signal) setting	[G E G : Δ Δ Δ 0 0 0]
Step 12	Press once the SKIP DOWN(◀◀) button.	Tracking ATT (F signal) setting	[G F G : Δ Δ Δ 0 0 0]
Step 13	Press once the SKIP DOWN(◀◀) button.	Indication of tracking EFMIO measurement (groove section)	[G M I : Δ Δ Δ _ _ _]
Step 14	Press once the SKIP DOWN(◀◀) button.	Focus ATT (A signal) setting	[L A G : Δ Δ Δ 0 0 0]
Step 15	Press once the SKIP DOWN(◀◀) button.	Focus ATT (B signal) setting	[L B G : Δ Δ Δ 0 0 0]

- If the MD STOP button is pressed twice while the MANUAL adjustment menu is displayed, the state is changed to the TEST mode STOP state.

8. TEST-PLAY mode

Step No.	Setting Method	Remarks	Display
Step 1	Test mode STOP state		[t s m 0 0 0 0 e 0 0]
Step 2	Press once the SOUND button.		[T E S T _ P L A Y _] ↓ [a □ □ □ c 0 0 0 0]
Step 3	Press the STOP button.		[T E S T _ P L A Y _]
Step 4	Press once the MD PLAY button.	During search the search output is set to "H", and it is returned to "L" when continuous playback is started.	
Step 5	Continuous playback (groove section)	(Address + C1 error indication)	
Step 6	Press once the MD STOP button.	TEST-PLAY menu	[T E S T _ P L A Y _]

- If the MD STOP button is pressed while the TEST-PLAY menu is displayed, TEST mode STOP state is set.
- If the MD PLAY button is pressed while the TEST-PLAY menu is displayed, continuous playback is started from the current pickup position.

CIRCUIT DESCRIPTION

9. TEST-REC mode

Step No.	Setting Method	Remarks	Display
Step 1	Test mode STOP state		[t s m 0 0 0 0 e 0 0]
Step 2	Press the SOUND button twice.		[T E S T _ R E C _ _] ↓ [a 0 0 0 0 p w ∇ ∇]
Step 3	Press the STOP button.		[T E S T _ R E C _ _]
Step 4	Press once the MD PLAY button.	During search the search output is set to "H", and it is (returned on "L" when continuous playback is started.Address + C1 error indication) Continuous recording	[a 0 0 0 0 p w ∇ ∇]
Step 5	Press once the MD STOP button.	TEST-REC menu	[T E S T _ R E C _ _]

- If the MD STOP button is pressed while the TEST-PLAY menu is displayed, TEST mode STOP state is set.
- If the MD PLAY button is pressed while the TEST-REC menu is displayed, continuous record is started from the current pickup position.
- If the (▶▶) or (◀◀) button in remote controller is pressed in TEST-REC mode and continuous record mode, the laser record power changes.
(Servo gain changes also according to the record power.)
- □□□□ : Adress, ∇∇ : Laser power cord

10. EJECT mode

Step No.	Setting Method	Remarks	Display
Step 1	Test mode STOP state		
Step 2	Test mode EJECT state	Eject of MD disc	[_ _ E J E C T _ _ _]
Step 3	Press SOUND button.	Temperature standard value setting.	[T E M P 0 0 ● ●]
Step 4	Press STOP button.		[_ _ E J E C T _ _ _]

- ○○ : Measurement value, ●● : Setting value.

• POWER

Display	TOC recording power	Actual power output	
		Value	Voltage
00H	2.50 mW	6E H	1.354 V
01H	2.60 mW	74 H	1.427 V
02H	2.70 mW	7B H	1.513 V
03H	2.85 mW	83 H	1.612 V
04H	3.00 mW	8A H	1.698 V
05H	3.15 mW	93 H	1.809 V
06H	3.30 mW	93 H	1.809 V
07H	3.45 mW	9C H	1.920 V
08H	3.60 mW	A6 H	2.043 V
09H	3.75 mW	AE H	2.141 V
0AH	3.95 mW	B9 H	2.289 V
0BH	4.15 mW	B9 H	2.289 V
0CH	4.35 mW	C4 H	2.412 V
0DH	4.55 mW	CF H	2.547 V
0EH	4.75 mW	DB H	2.695 V
0FH	5.00 mW	DB H	2.695 V

8. MD mechanism error message

DISPLAY	DESCRIPTION
BLANK DISC	Non Recorded disc
CAN'T COPY	Inhibit to record by SCMS
CAN'T EDIT	Inhibit to edit by MD standard
CAN'T REC	Inhibit to record by disc damage(10 or more defects/recordable cluster is 0)
DISC ERROR**	OR : UTOC read error or FTNO>LTNO (edit/record) permit ALL ERASE only DO : Start address TNO>endless TNO (playback) handle poor TNO as 1SG (edit/record) permit ALL ERASE only C0 : Write poor data in UTOC0 C1 : Write poor data in UTOC1 C2 : Write poor data in UTOC2 C4 : Write poor data in UTOC4 (play back) playback even if address roof(C0) (edit/record) permit ALL ERASE only
DISC FULL	No recordable area
MECH ERR**	10-13 : head poor down 20-23 : head poor up
no disc	No disc in the unit
NO TRACKS	Disc recorded title only
NOT AUDIO	Disc recorded audio signal.
PLAY ONLY	Record to music disc
PROTECTED	Record disc inhibited to record
READING	In mode of reading TOC or UTOC
SRCH ERR**	30 : Search time over in playback, FF or FB 31 : Search time over in REC-PAUSE 32 : Search time over in record
TEMP OVER	High temperature
TITLE FULL	Input over letter of title
UNIT ERROR	Hardware damage
UTOC W ERR	Error of writing to UTOC
WRITING	In writing to UTOC

RXD-M32MD

CIRCUIT DESCRIPTION

5. Main Microprocessor : X29(IC104) M30622MA-1A5FP (DECK VERSION) M30624MG-307FP (MD VERSION)

5-1 Main Microprocessor Periphery Block Diagram

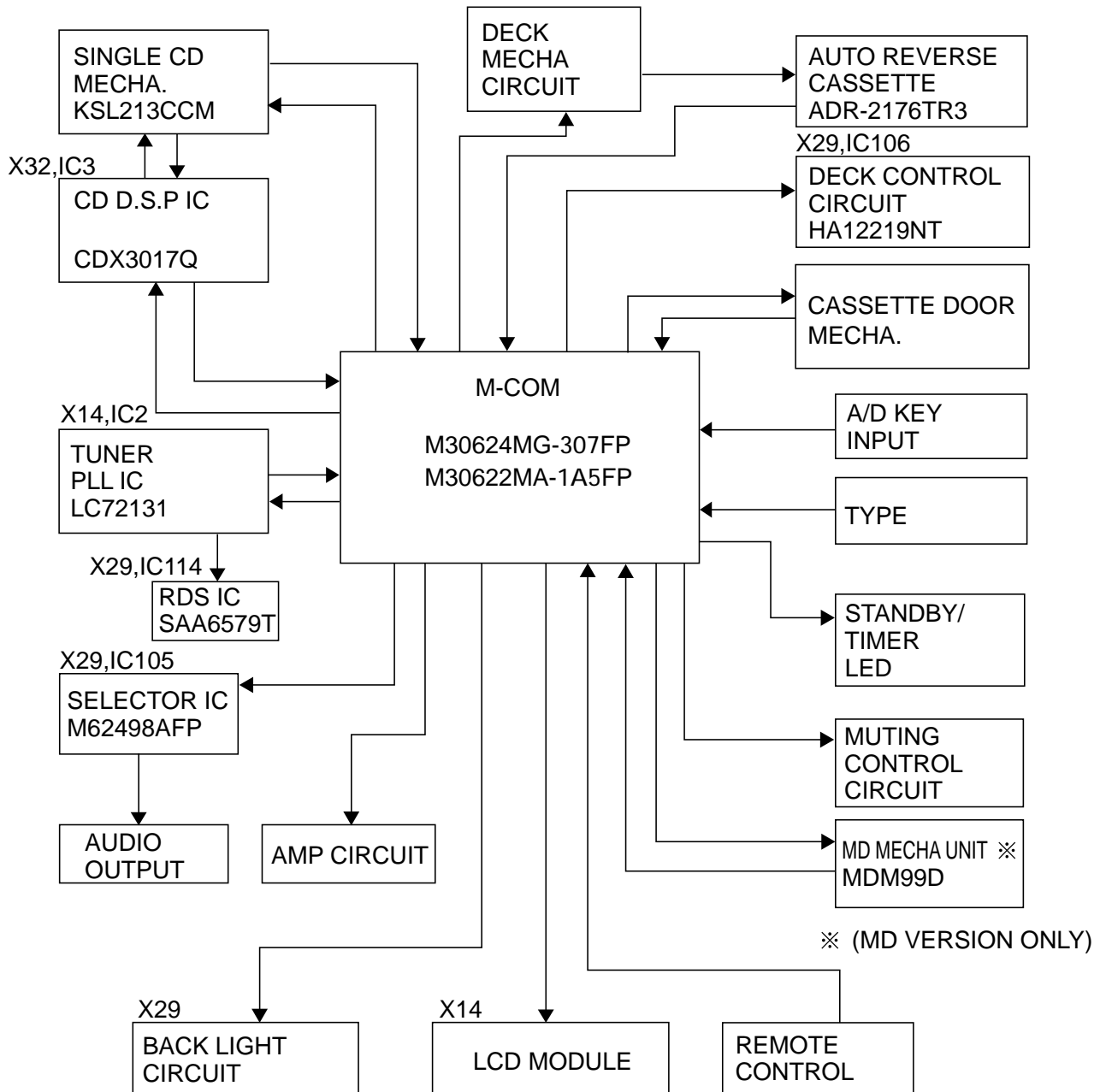

5-2. Key Matrix

INPUT VOLTAGE(V)	KEY1 Pin90	KEY2 Pin91
0.00~0.23	TUNER/BAND	SET/ DEMO
0.24~0.67	STOP	MENU
0.68~1.12	TAPE REC	SKIP UP
1.13~1.60	TAPE PLAY (F PLAY)	SKIP DOWN
1.61~2.02	MD REC (TAPE O.T.E.)	SOUND
2.03~2.74	MD PLAY (R PLAY)	AUX
2.75~2.47	MD EJECT (TAPE EQ)	-
2.48~3.37	CD PLAY	-
3.38~3.82	CD OPEN/CLOSE	-
3.83~4.27	POWER	-
4.28~4.74	TAPE OPEN/CLOSE	-
4.75~5.00	KEY OFF	KEY OFF

* Vref=5V

() Deck version

CIRCUIT DESCRIPTION

5-3 Pin Description of Main Microprocessor

Pin No.	Pin Name	I/O	Description		
1	CD_PROTECTION	I	Detection port for CD protection.	H = NORMAL	L = PROTECTION ON
2	CD_OPEN_SW	I	CD open detection switch input.	H = OFF	L = ON
3	CD_OPEN_M	O	CD tray motor control output (open).	H = OFF	L = ON
4	CD_CLOSE_M	O	CD tray motor control output (close).	H = OFF	L = ON
5	CD_CLOSE_SW	I	CD close detection switch input.	H = ON	L = OFF
6	RDS_DATA	I	RDS data input.		
7	CE	I	Power failure input port.	H = AC ON	L = AC OFF
8	BYTE	I	GND.		
9	CNVSS	I	GND.		
10	XCIN	I	Timer clock input (32.768kHz).		
11	XCOU	O	Timer clock output (32.768kHz).		
12	RESET	I	Reset signal input for microprocessor.	H = NORMAL	L = RESET
13	XOUI	O	Main clock oscillator(10MHz).		
14	VSS	I	GND.		
15	XIN	I	Main clock oscillator(10MHz).		
16	VCC(B.U)	I	Power supply(+5.0v).		
17	NMI	I	Connected to VCC.		
18	REMOCON	I	Remote control signal input.		
19	RDS_CLK	I	RDS clock input.		
20	SCOR	I	Sub code synchronized signal input.		
21	SCLK	O	CD sense data read out clock.		
22	SENSE	I	CD sense input.		
23	CD_CLK	O	CD DSP clock output.		
24	XLAT	O	CD DSP latch output.		L = LATCH
25	CD_DATA	O	CD DSP data output.		
26	SYSM	O	CD DSP system mute output.		
27	CDRST	O	CD DSP reset signal output.		
28	SQCK	O	CD sub code clock output.		
29	SUBQ	I	CD sub code input.		
30	NC	O	Unused.		
31	K_DATA	O	MD data output (MD version only).		
32	MD_DATA	I	MD data input (MD version only).		
33	MD_SCK	O	MD clock output (MD version only).		
34	LED2	O	Control port of standby/timer LED (red).	L = ON	
35	LCD_DATA	O	Data output to LCD driver IC.		
36	NC	O	Unused.		
37	LCD_CLK	O	Clock output to LCD driver IC.		
38	LED1	O	Control port of standby/timer LED (green).	L = ON	
39	ENC1	I	Rotary encoder input (up).		
40	ENC2	I	Rotary encoder input (down).		
41	DECK_CMP	O	Deck capstan motor control.		
42	DECK_SOL	O	Deck solenoid control.		
43	PLAY_SW	I	Deck play switch input.		
44	CrO2_SW	I	Deck CrO2 detection switch input.	H = CrO2	L = Normal
45	PACK_SW	I	Deck pack switch input.	H = OFF	L = ON
46	REC_F_SW	I	Deck forward rec switch input.	H = OFF	L = ON
47,48	NC	-	Unused.		
49	REC_R_SW	I	Deck reverse rec switch input.	H = OFF	L = ON
50	NORMAL_BIAS	O	Deck bias (Normal/CrO2) change-over.		

RXD-M32MD

CIRCUIT DESCRIPTION

Pin No.	Pin Name	I/O	Description		
51	REC/PLAY	O	Deck rec/play control.		
52	BIAS	O	Deck bias control.		
53	120/70	O	Deck EQ. control.		
54	A/B-1	O	Mode selection for deck.		
55	A/B-2	O	Mode selection for deck.		
56	B-1/2	O	Mode selection for deck.		
57	SD	I	SD detector input.	H = NO TUNED	L = TUNED
58	STEREO	I	Stereo detector input.	H = MONO	L = STEREO
59	PLL_DATA	O	PLL IC data output.		
60	PLL_DO	I	PLL IC data input.		
61	PLL_CE	O	PLL IC chip enable.		
62	VCC(B.U)	I	Power supply(+5.0v).		
63	PLL_CLK	O	PLL IC clock output.		
64	VSS	I	GND.		
65	VOL_CLK	O	Clock output to selector IC.		
66	VOL_DATA	O	Data output to selector IC.		
67	CLOSE_SW	I	Close detection switch input for CD door.	H = OF F	L = ON
68	OPEN_SW	I	Open detection switch input for CD door.	H = OF F	L = ON
69	DOOR F	O	CD door (open) control output.	H = ON	L = OFF
70	DOOR R	O	CD door (close) control output.	H = ON	L = OFF
71	LCD_RST	O	Reset signal output to LCD driver IC.	H = NORMAL	L = RESET
72	LCD_CS	O	CS signal output to LCD driver IC.		
73	BACK_LIGHT	O	Back light control output.		
74	SP_RELAY	O	Speaker relay control output.	H = ON	L = OFF
75	PROTECTION	O	Detection input port for protection circuit	H = PROTECTION ON	
76	H.P SW	I	Headphones detection input.	H = OFF	L = ON
77	A_MUTE	O	Audio muting control output.	H = OFF	L = ON
78	B.U SW	O	Unused.		
79	DSTB	I	MD STB input port.		
80	SEARCH	O	MD search output.		
81	MD_ST	O	MD ON/CD sync. output.		
82	MD_RST	O	Reset signal output to MD.		
83	LOAD SW	I	Loading switch input from MD.		
84	PDOWN	O	MD power supply.	H = ON	L = OFF
85	P.RELAY	O	Power relay control output.	H = ON	L = OFF
86	CD_POWER	O	CD power ON/OFF control.	H = NORMAL	L = AC OFF
87	CD_MON	O	CD monitor output.	H = ON	L = OFF
88	CD_SPEED	O	Speed control port for CD.	H = ON	L = OFF
89	M TYPE CE	O	Unused.		
90	KEY1	I	A/D key (key1) input port.		
91	KEY2	I	A/D key (key2) input port.		
92	RDS_SLEVEL	I	RDS Slevel input.		
93	MD_BUP(NC)	I	Detection port for MD back up.		
94	PHOTO	I	Detection port for deck reel pulse.		
95	TYPE	I	Discrimination port for destination.		
96	AVSS	I	GND.		
97	CD DIFFECT	I	Unused.		
98	VREF	I	A/D reference voltage(+5V).	(No backed up 5V)	
99	AVCC	I	A/D reference voltage(+5V).	(backed up 5V)	
100	NC	O	Unused.		

ADJUSTMENT

CD player adjustment

No.	ITEM	INPUT SETTING	OUTPUT SETTING	PLAYER SETTING	ALIGNMENT POINT	ALIGN FOR	FIG.
TEST MODE: While pressing the CD PLAY key, turn the power on.							
1	* LASER POWER	—	Set the sensor section of the optical power meter on the pickup lens.	Press the "PLAY" key to check that the display is "03".	—	On the power from 0.05 to 0.15mW. when the diffraction grating is correctly aligned with the RF level of 0.8Vp-p or more	(a)
2	LASER CURRENT	Test disc Type 4	Connect the DC voltmeter to CN3 (③, ④) on X32.	Press the "PLAY" key to check that the display is "03" or "05"	—	220mV to 550mV	
3	FOCUS ERROR BIAS	Test disc Type 4	Connect an oscilloscope as follows. CH1: RF(CN3, ①) GND: VC(CN3, ②) * X32	Press the "PLAY" key. Confirm that the display is "05".	VR 1	Optimum eye pattern	(d)

Note:

Type 4disc :SONY YEDS-18 Test Disc or equivalent. (KTD-02)

LPF : Around 47kΩ + 390pF or so.

(a) Laser Power

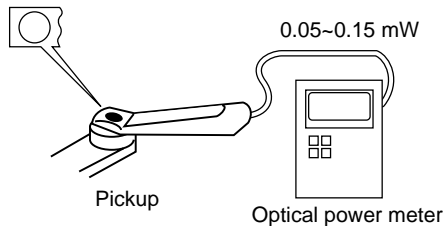

* How To Check the Laser Power

1. Set the test mode.
(The CD tray is opened automatically.)
2. To close the CD tray, press the OPEN/CLOSE key.
3. Move the pickup to outward by pressing the TAPE REC key.

(d) RF signal: AC coupled

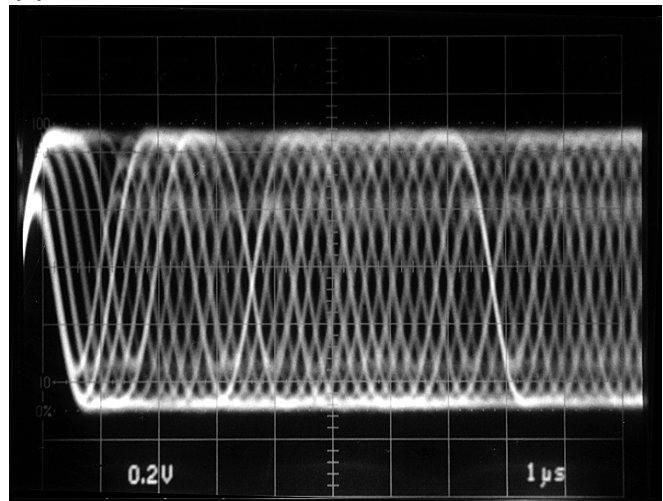

- RF signal in test mode (PLAY).
- Perform the tangential and focusing offset are focused into one point on the display. The crossing points above and below the center shall also be looked clearly.

RXD-M32MD

ADJUSTMENT

Cassette deck adjustment

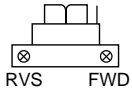
NO.	ITEM	INPUT SETTING	OUTPUT SETTING	CASSETTE TAPE DECK SETTING	ALIGNMENT POINTS	ALIGN FOR	FIG.
Unless otherwise specified, set the respective switches as follows:						0dBs = 0.775V	
TAPE : NORMAL							
I Cassette mechanism unit (Adjustment of the REC / PLAY head)							
(1)	Demagnetization and cleaning			Power : OFF Demagnetization, cleaning, PLAY	Recording head, erase head, capstan pinch roller	Demagnetize the REC / PLAY head with the head eraser. Clean the REC/PLAY head, erase head, capstan and pinch roller using a cotton swab slightly damped with alcohol.	
(2)	Azimuth of the REC / PLAY head	SCC-1727 TCC-153 MTT-114 10kHz, -10dB	(B)	PLAY		Adjust the output to maximum and adjust the azimuth adjustment screw for the Lissajours waveform pattern of the oscilloscope to become close to a 45β straight line.	
II PC board adjustment.							
(1)	BIAS CURRENT	(A) Adjust the AG for the output of the DECK to become -20dBs at 12.5kHz/400Hz. (AC-224)	(B)	REC PLAY	VR101(L) VR102(R)	Record 400Hz and 12.5kHz alternately, and adjust the bias current adjustment potentiometer for the playback levels to become the same.	

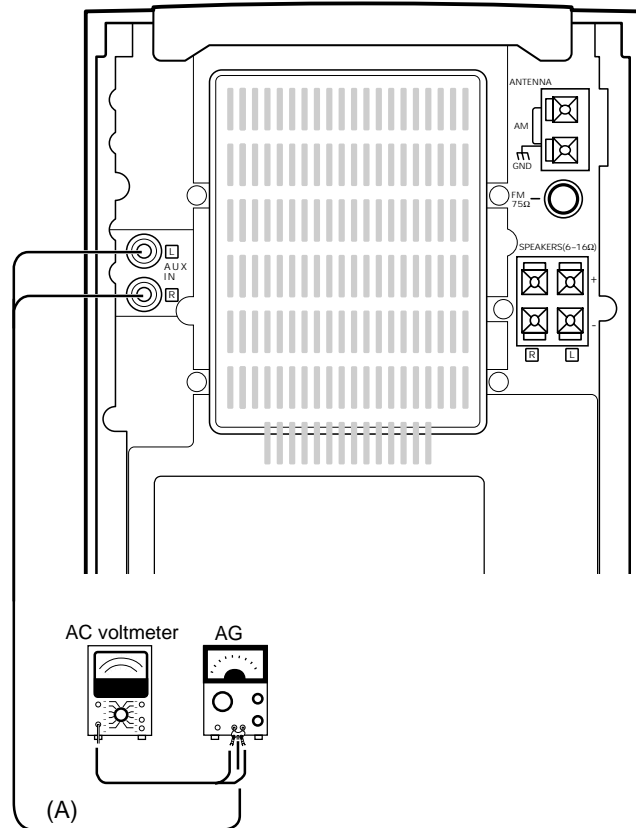
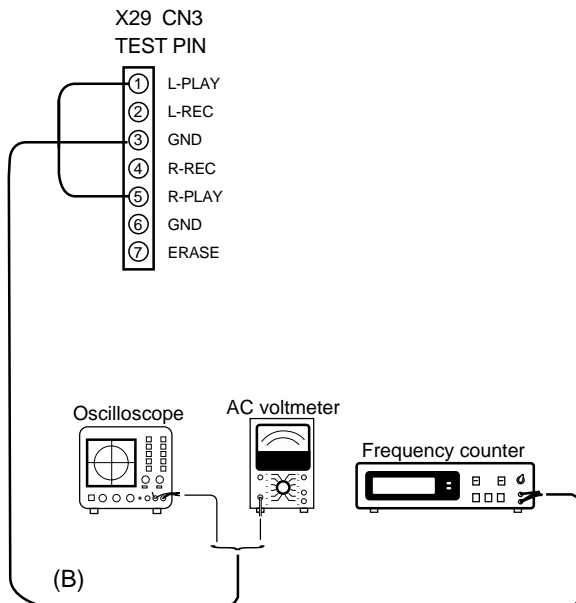

ADJUSTMENT

Tuner adjustment

No.	ITEM	INPUT SETTINGS	OUTPUT SETTINGS	RECEIVER SETTINGS	ALIGNMENT POINTS	ALIGN FOR	FIG.
FM SECTION : SELECTOR : FM *Adjust NO.1 and NO.2 repeat.							
1	DISCRIMINATOR	(A) 98.0MHz 1kHz, ±40kHz dev. 70dBf (ANT. input)	Connect a DC voltmeter between CN4 ① and CN4 ② (X14)	MONO 98.0MHz	L4 (X14-)	0V	
2	DISTORTION (MONO)	(A) 98.0MHz 1kHz, ±40kHz dev. MONO 70dBf (ANT. input)	(B)	MONO 98.0MHz	L5 (X14-)	Minimum distortion	
3	DISTORTION (STEREO)	(C) 98.0MHz 1kHz, ±40kHz dev. Selector : L or R Pilot : ±6kHz dev. 70dBf (ANT. input)	(B)	AUTO 98.0MHz	IFT(RF FRONTEND : A1) (X14-)	Minimum distortion (L or R)	
4	TUNING LEVEL	(A) 98.0MHz MONO 1kHz, ±40kHz dev. 30dBf (ANT. input)	—	MONO 98.0MHz	VR1 (X14-)	Adjust VR1 and stop at the point where ED1 (TUNED) goes on.	

SYSTEM CONNECTIONS

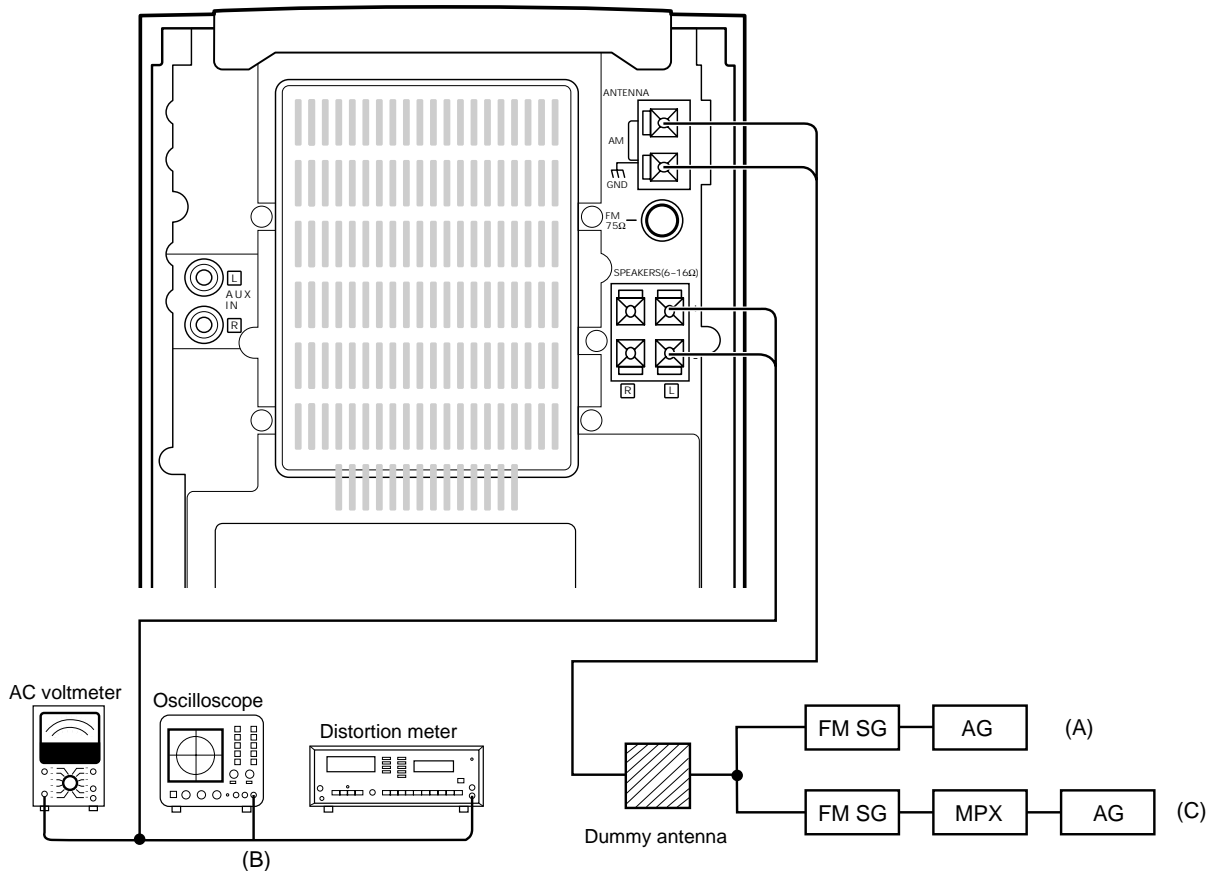

PC BOARD (Component side view)

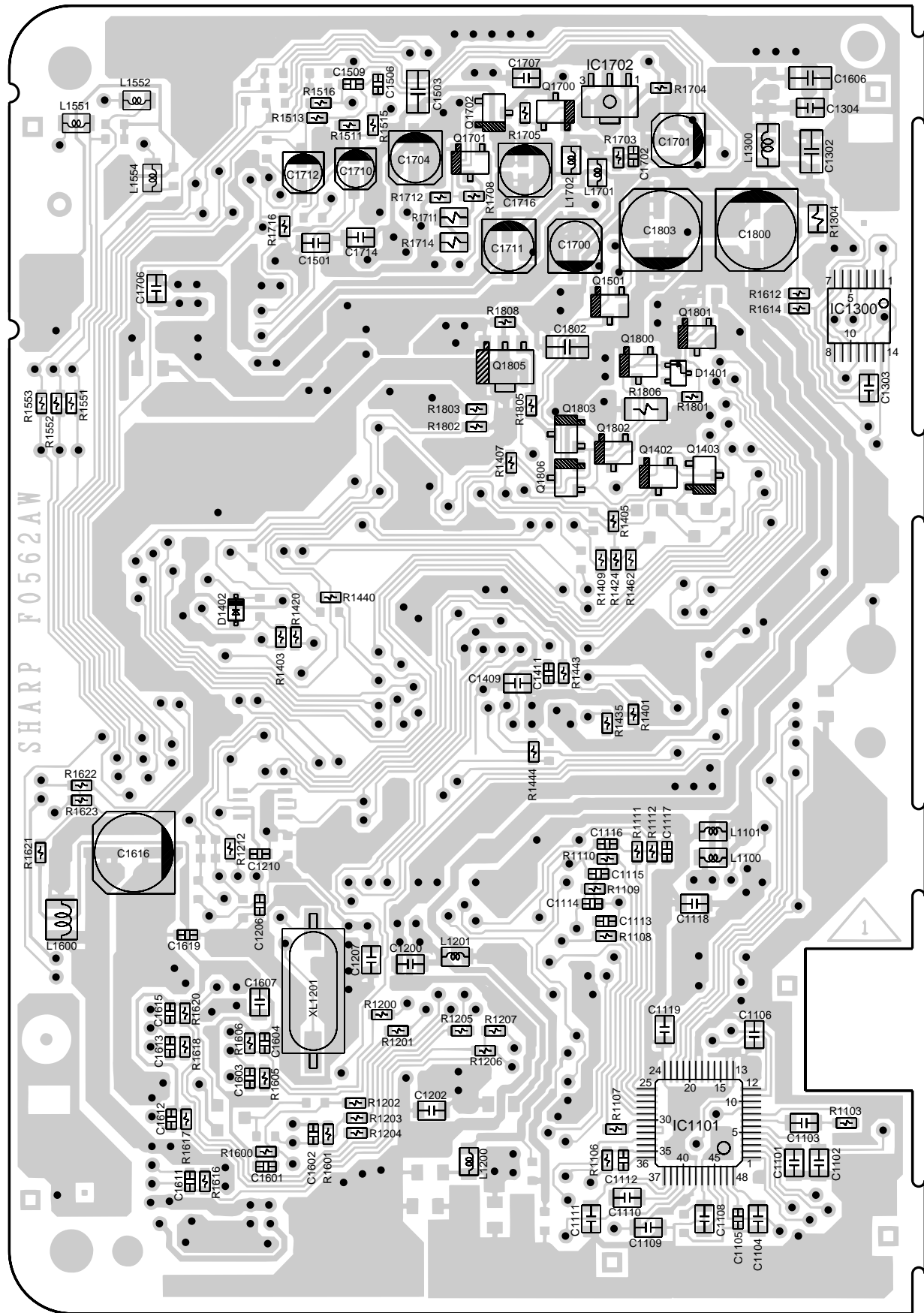

MD MAIN PWB-E (TOP VIEW)

Refer to the schematic diagram for the value of resistors and capacitors.

PC BOARD(Component side view)

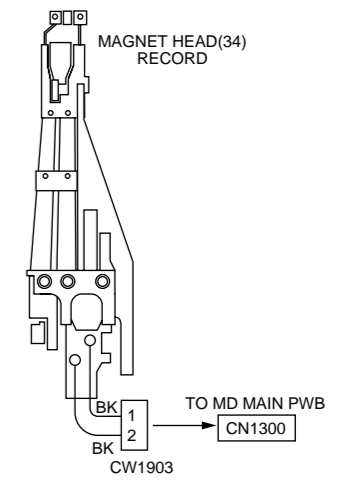
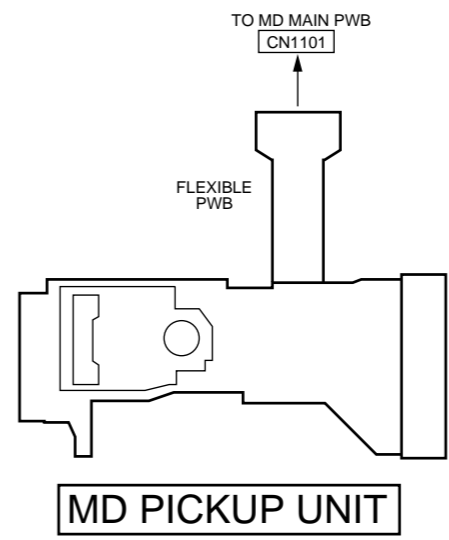
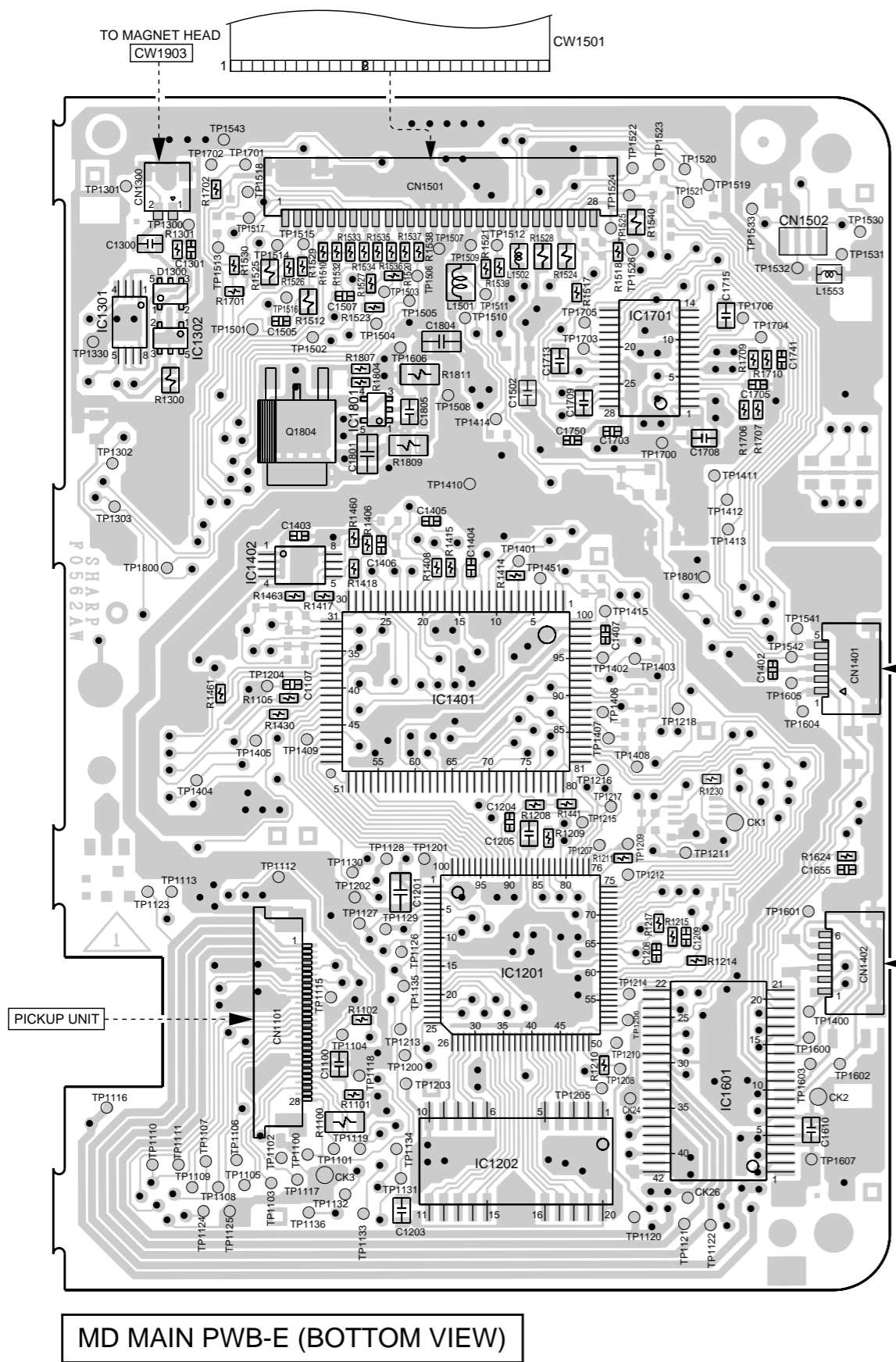

MD MECHANISM SWITCH PWB-F1

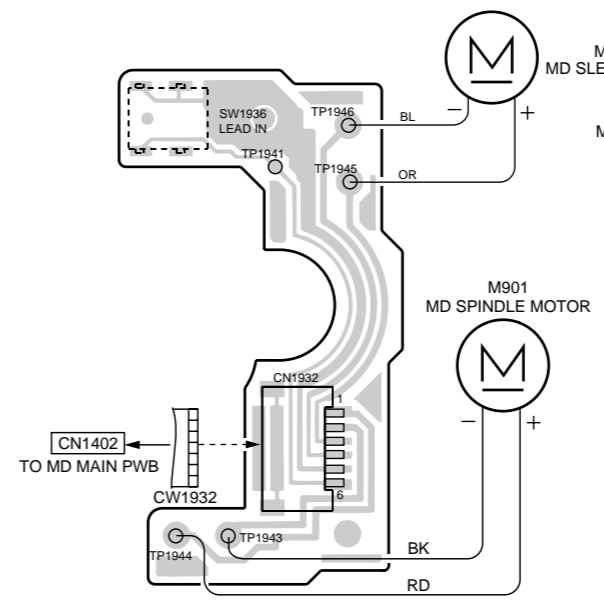

MD LOADING PWB-F2

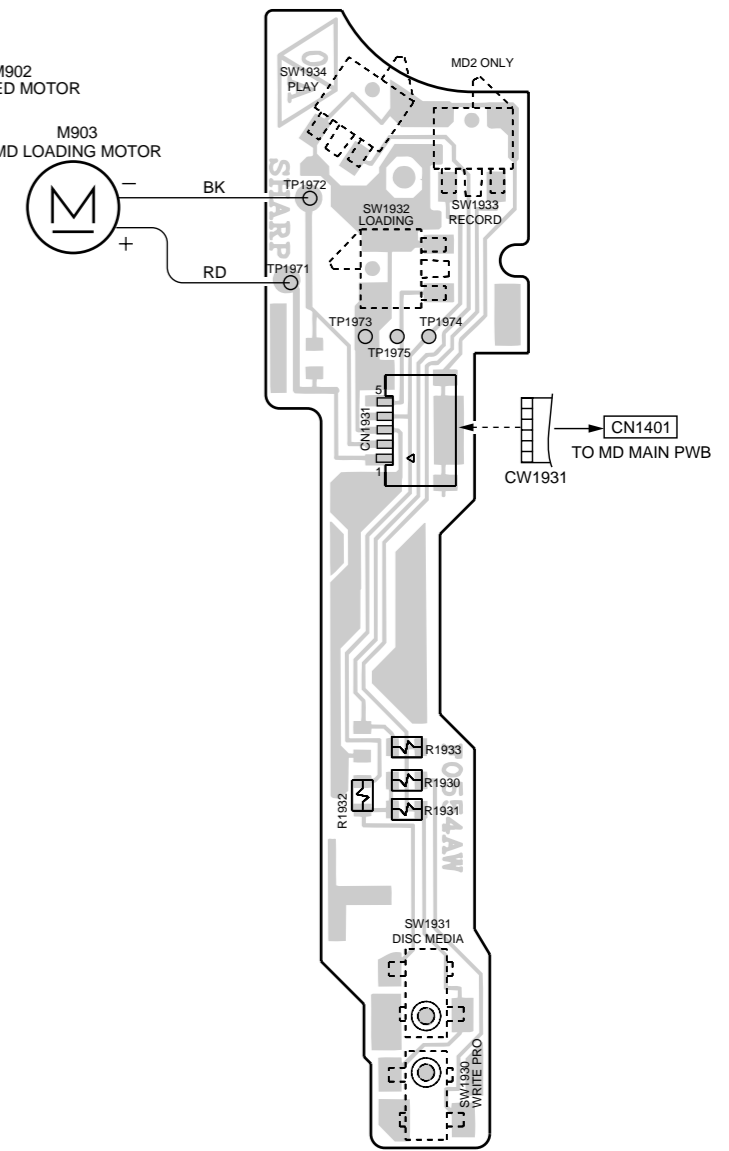

MD MAIN PWB-E (BOTTOM VIEW)

Refer to the schematic diagram for the value of resistors and capacitors.

PC BOARD(Component side view)

**X14-7140-00 A/6
(J70-1404-11) ANTENNA**

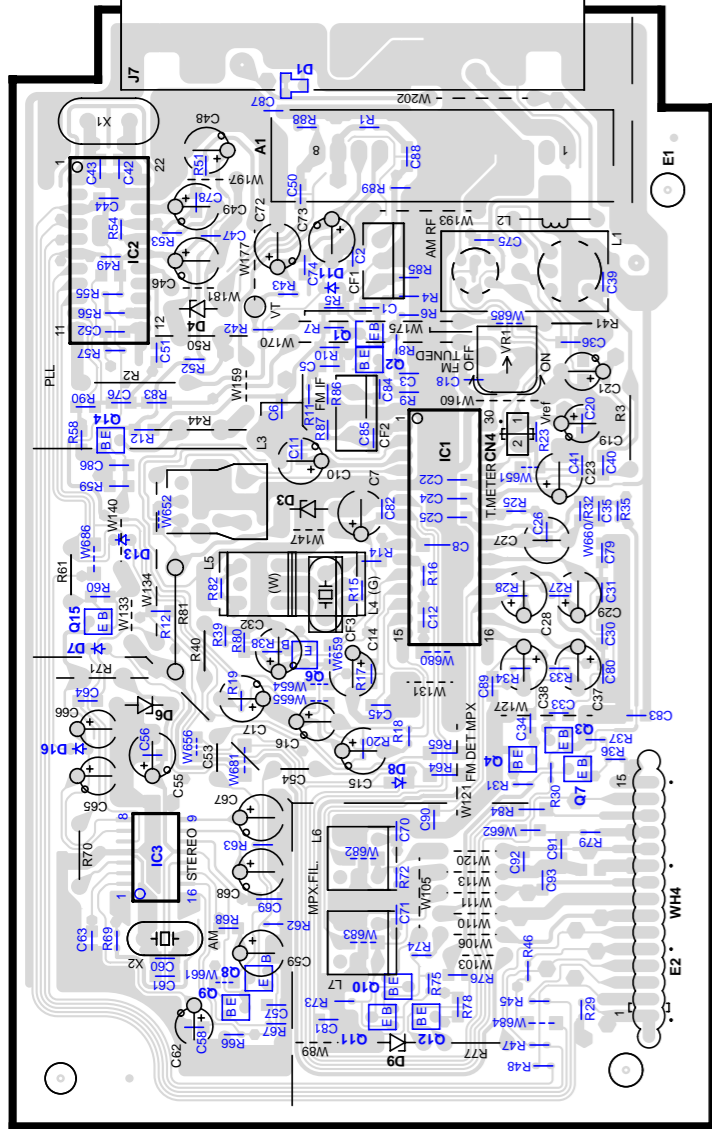

X14 F/6

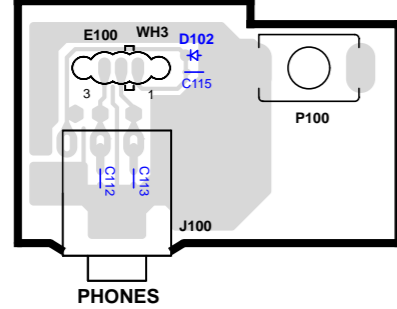

X14 D/6

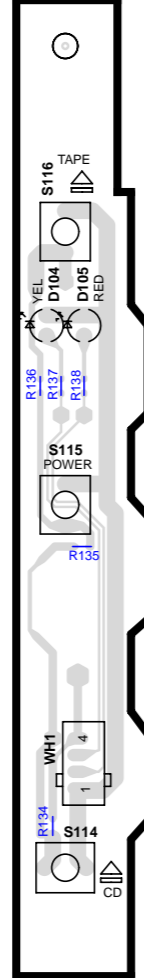

X14 B/6

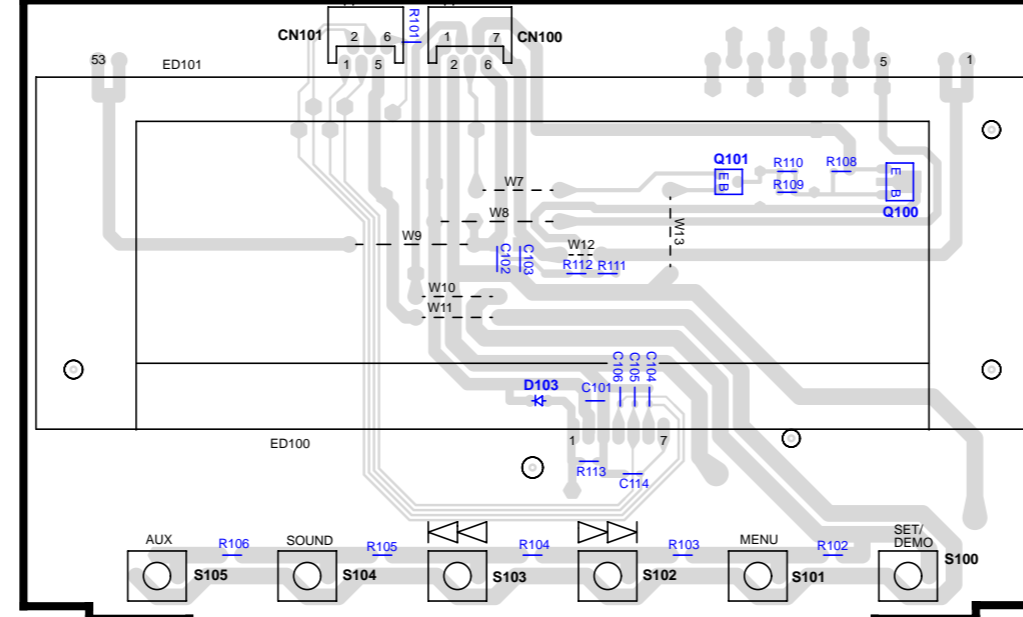

X14 E/6

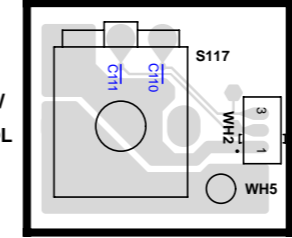

X14 C/6

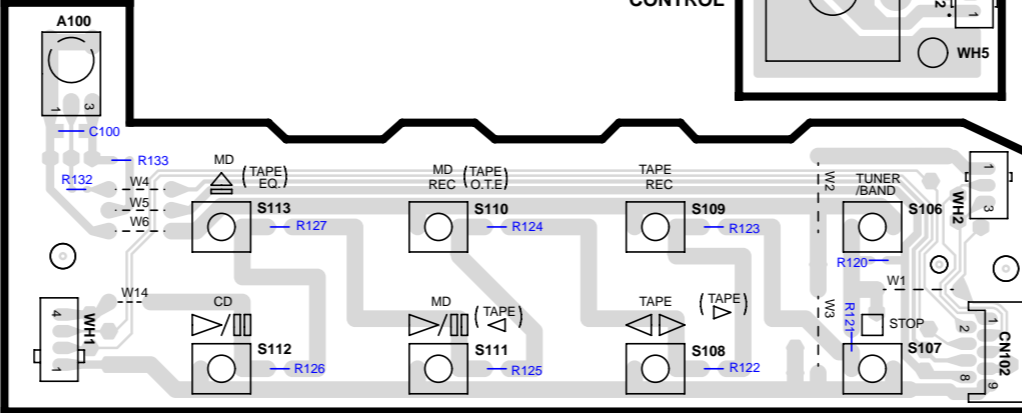

X32-3810-00 (J70-1406-02)

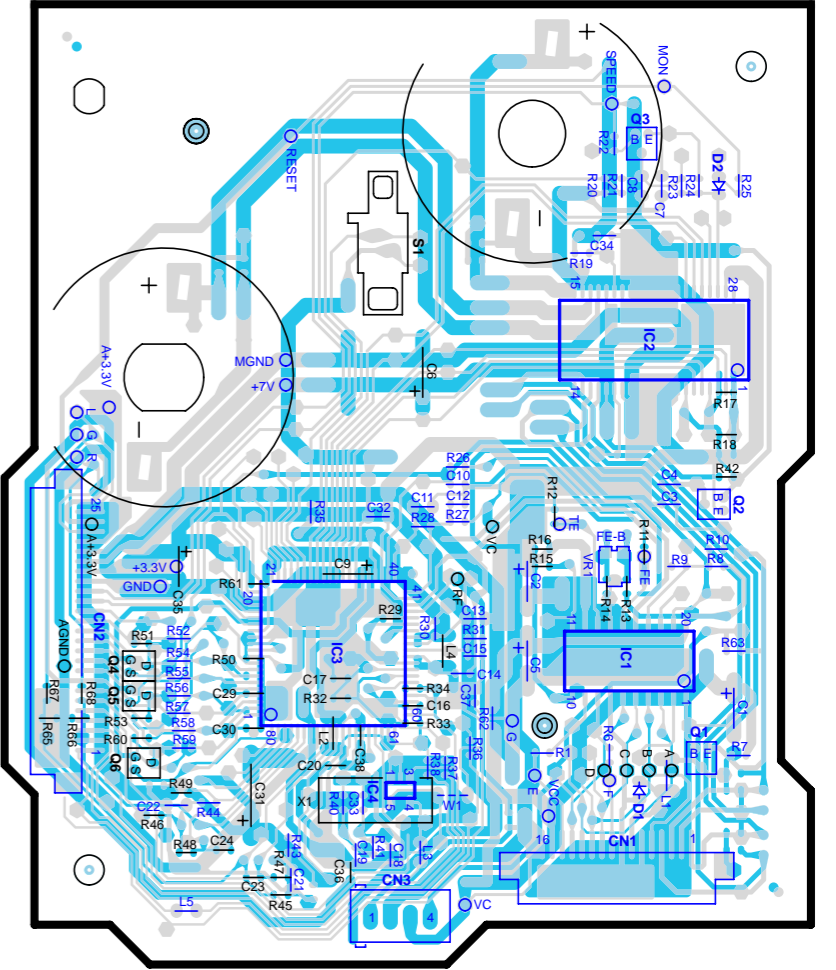

PC BOARD(Component side view)

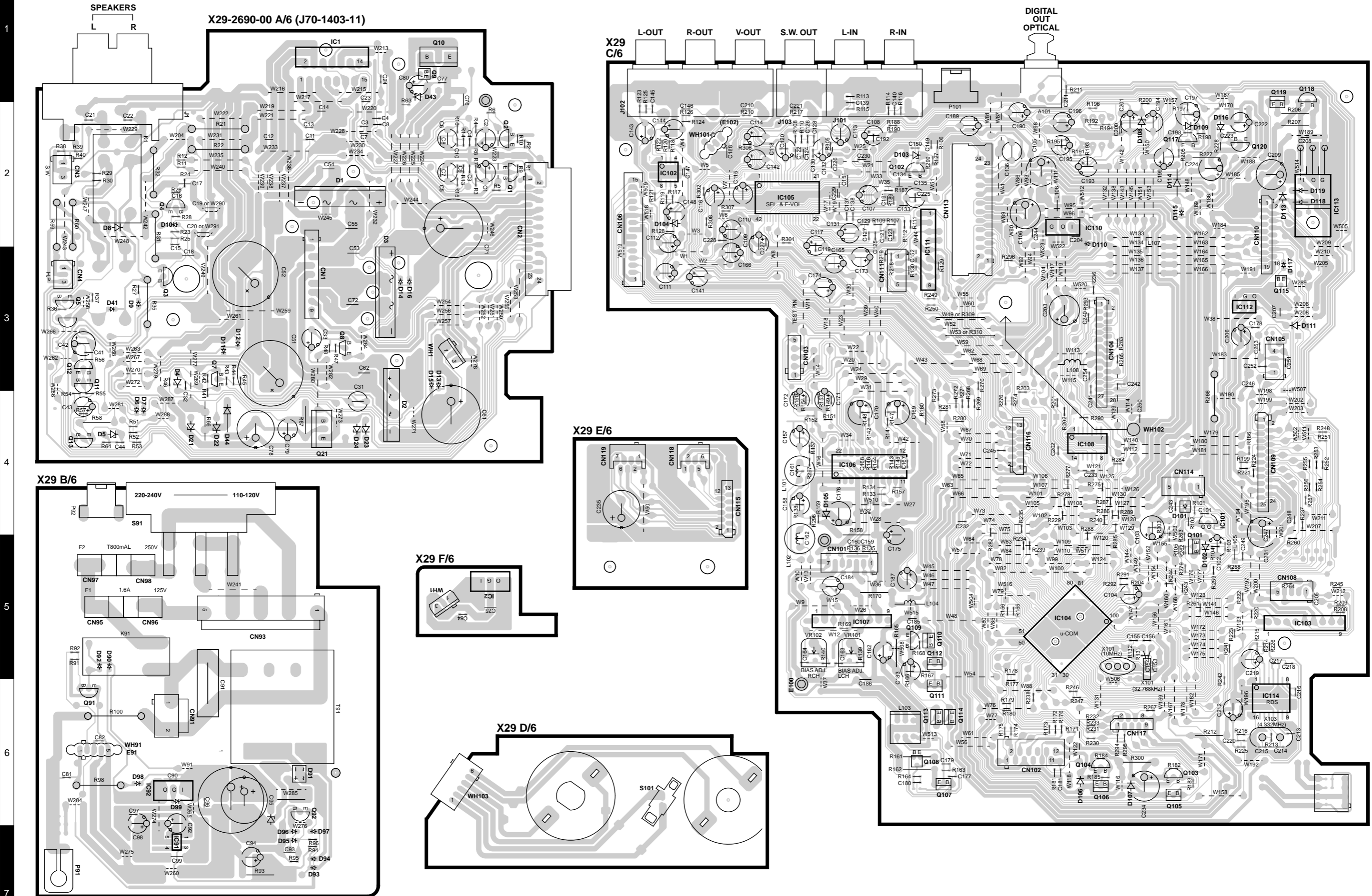

Refer to the schematic diagram for the value of resistors and capacitors.

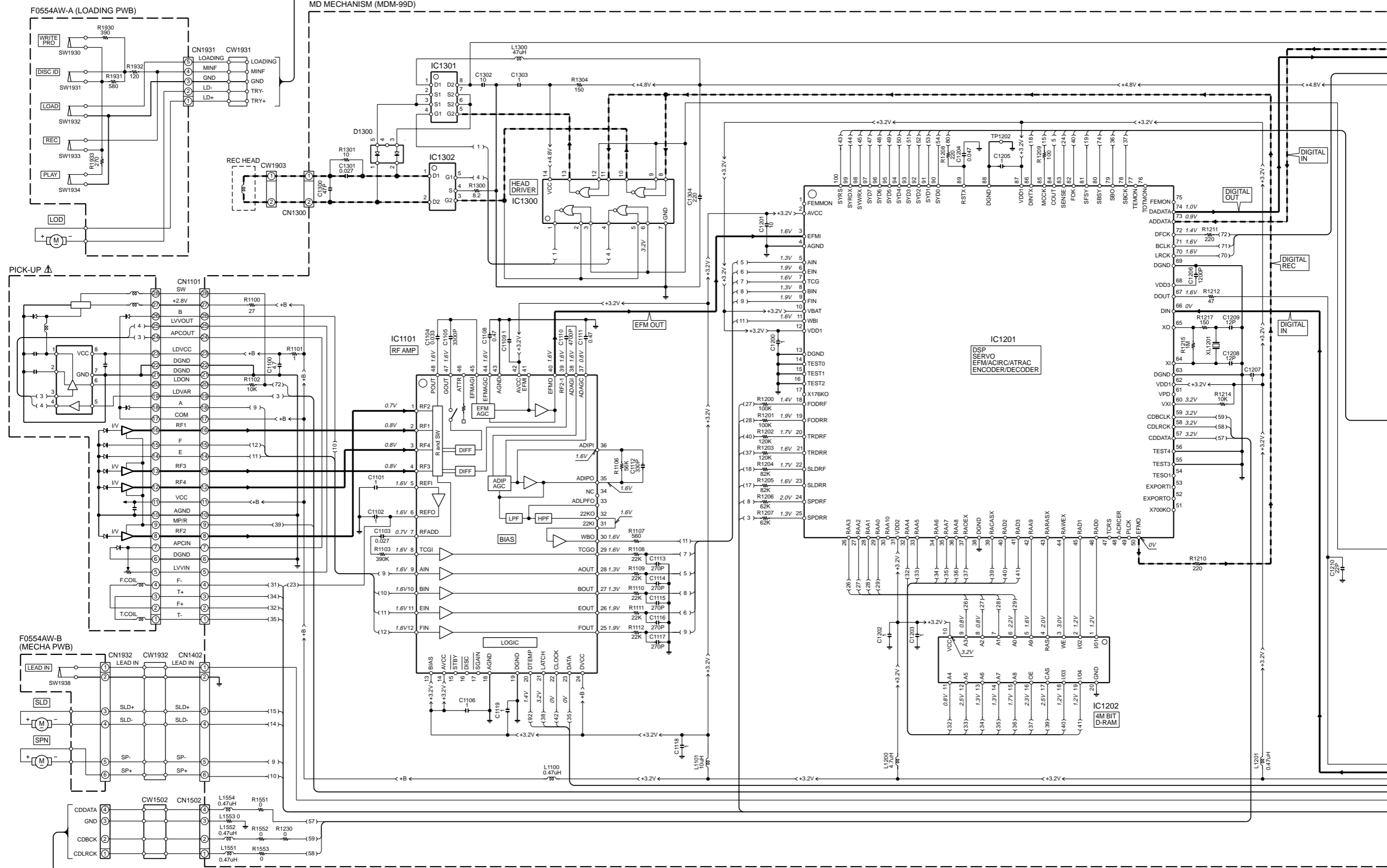

CAUTION: For continued safety, replace safety critical components only with manufacturer's recommended parts (refer to parts list). Δ indicates safety critical components. For continued protection against risk of fire, replace only with same type and rating fuse(s). To reduce the risk of electric shock, leakage-current or resistance measurements shall be carried out (exposed parts are acceptably insulated from the supply circuit) before the appliance is returned to the customer.

The DC voltage is an actual reading measured with a high impedance type voltmeter. The measurement value may vary depending on the measuring instruments used or on the product. Refer to the voltage during RECORDABLE MD PLAY unless otherwise specified; The value shown in () is the voltage measured at the moment of STOP. The voltage followed by (REC) refers to the value during MD RECORDING.

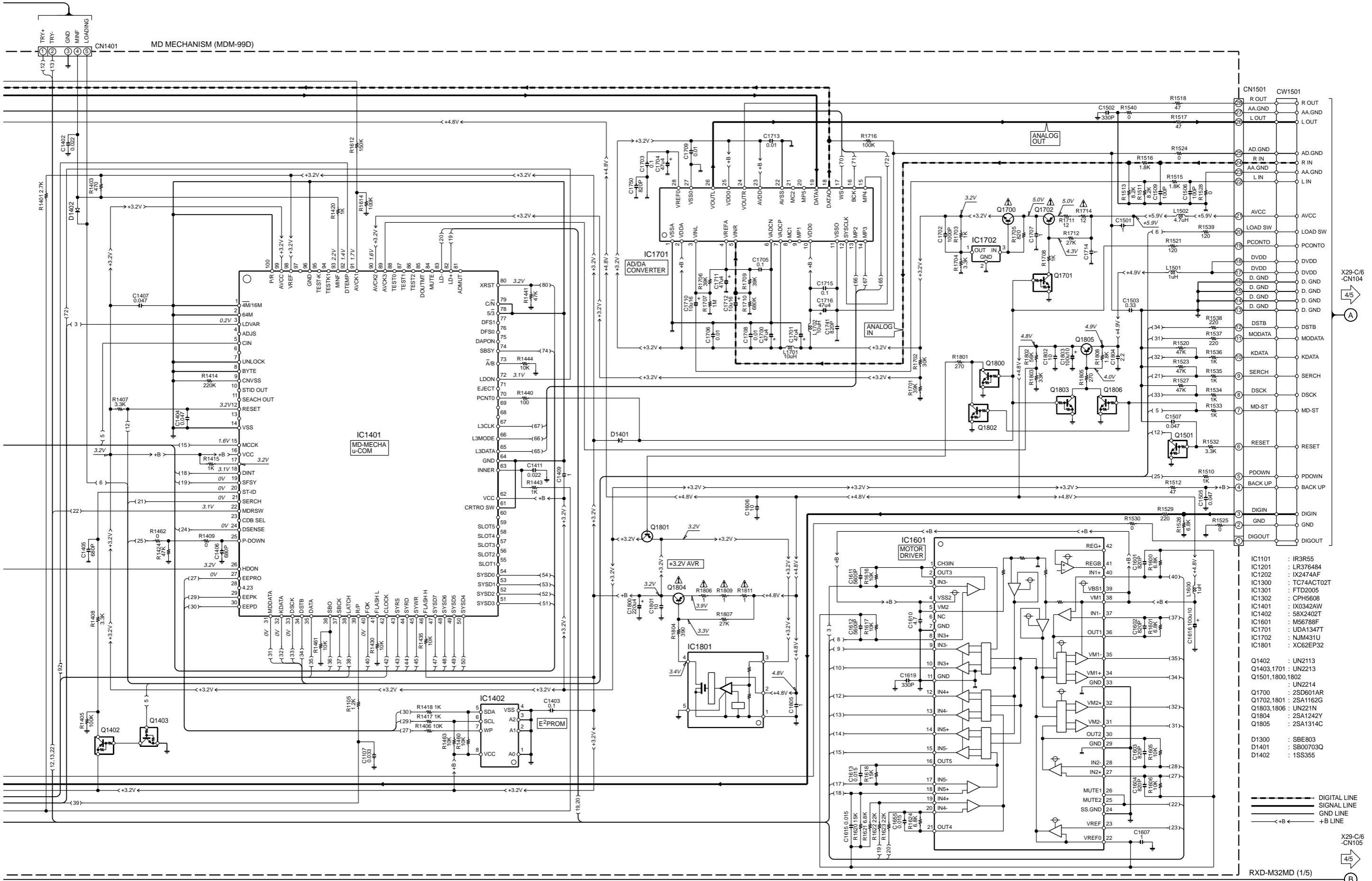

- IC1101 : IR385
 - IC1201 : LR376484
 - IC1202 : IX2474AF
 - IC1300 : TC74ACT02T
 - IC1301 : FTD2005
 - IC1302 : CPH5608
 - IC1401 : IX0342AW
 - IC1402 : 58X2402T
 - IC1601 : M56788F
 - IC1701 : UDA1347T
 - IC1702 : NJM431U
 - IC1801 : XC62EP32
- Q1402 : UN2113
 - Q1403,1701 : UN2213
 - Q1501,1800,1802 : UN2214
 - Q1700 : 2SD601AR
 - Q1702,1801 : 2SA1162G
 - Q1803,1806 : UN221N
 - Q1804 : 2SA1242Y
 - Q1805 : 2SA1314C
- D1300 : SBE803
 - D1401 : SB00703Q
 - D1402 : 1SS355

--- DIGITAL LINE
 --- SIGNAL LINE
 --- GND LINE
 --- +B LINE

RXD-M32MD (1/5)

RXD-M32MD

Y39-3520-21

KENWOOD

TUNER UNIT (X14-714X-XX) (A/6)

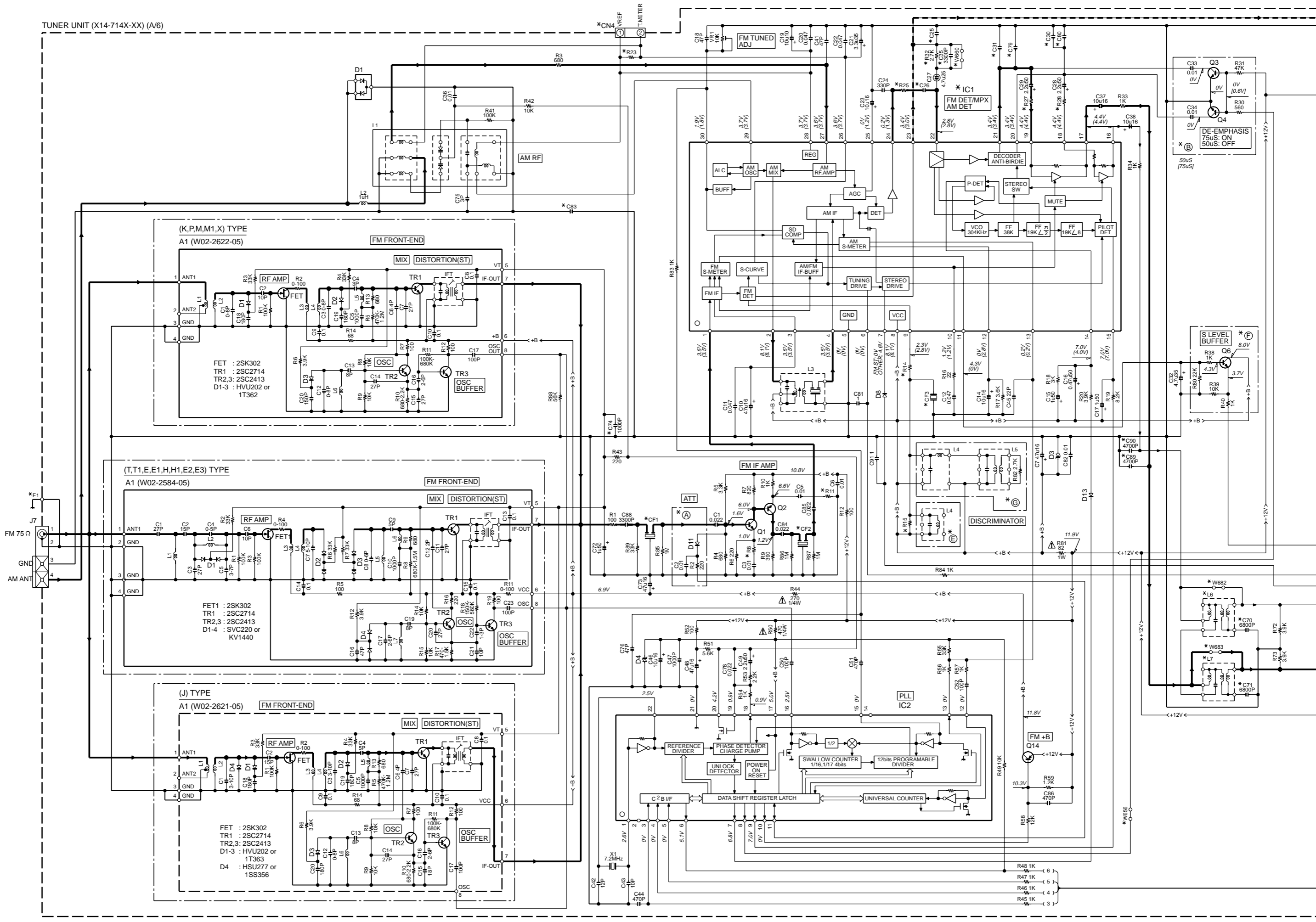

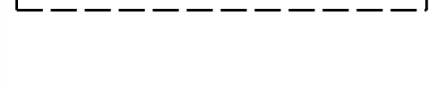
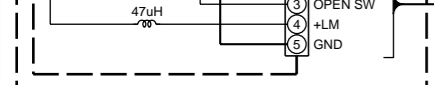
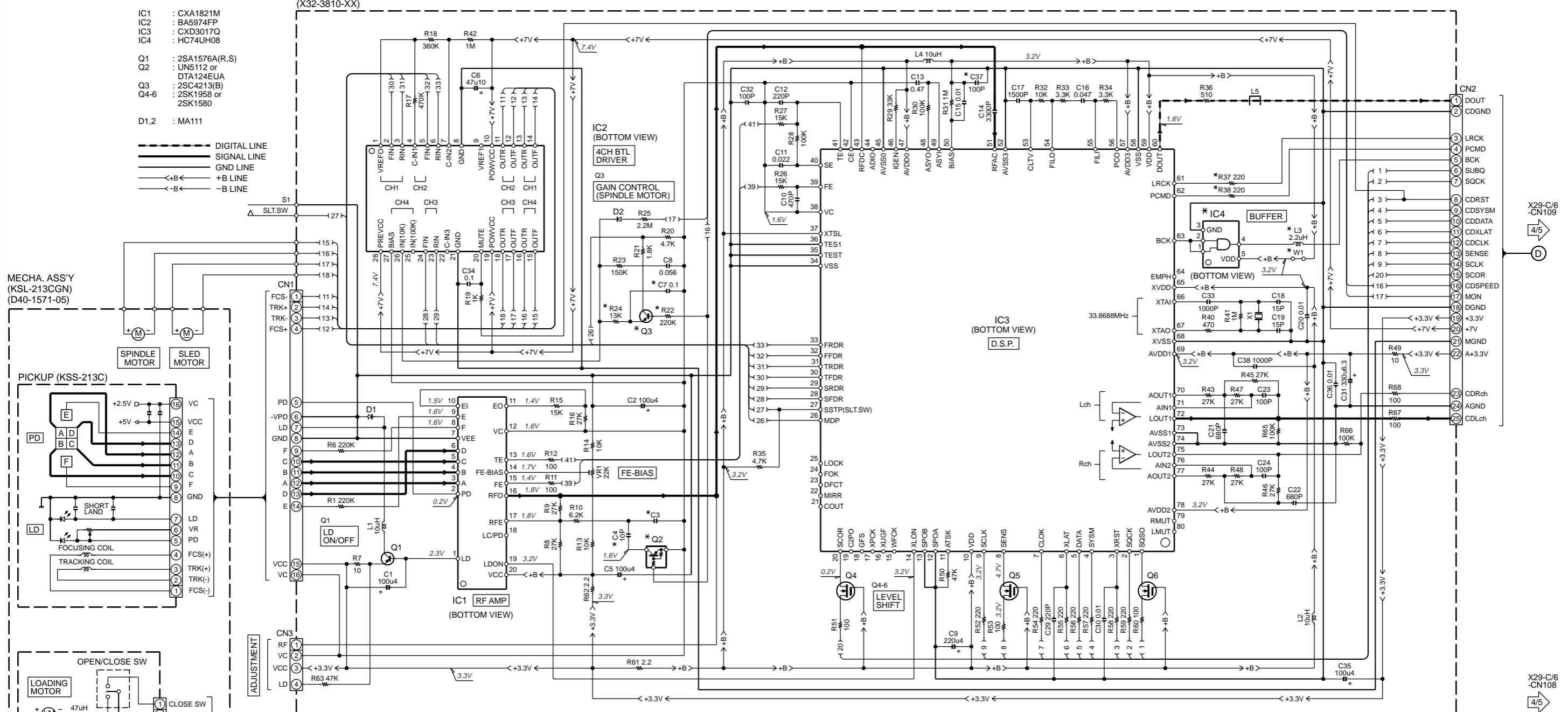

RXD-SH3MD-L/SH3MD-S/SH3MD-H/SH3MD-LS/SH3MD-W (X32-3810-00)

DESTINATION	COUNTRY	ABB.	UNIT No.	R22,24,37,38	C3	C4,7	C37	Q2,3	L3	W1	IC4
JAPAN	J	0-00	YES	15P	YES	NO	YES	YES	YES	YES	YES

RXD-SH3MD-Y (X32-3810-00)

DESTINATION	COUNTRY	ABB.	UNIT No.	R22,24,37,38	C3	C4,7	C37	Q2,3	L3	W1	IC4
JAPAN	J1	0-00	YES	15P	YES	NO	YES	YES	YES	YES	YES

RXD-SH3MD-D (X32-3810-00)

DESTINATION	COUNTRY	ABB.	UNIT No.	R22,24,37,38	C3	C4,7	C37	Q2,3	L3	W1	IC4
JAPAN	J2	0-00	YES	15P	YES	NO	YES	YES	YES	YES	YES

RXD-M32MD-S/M32MD-LS/M32MD-L (X32-3810-00)

DESTINATION	COUNTRY	ABB.	UNIT No.	R22,24,37,38	C3	C4,7	C37	Q2,3	L3	W1	IC4
U.K.	T	0-00	YES	15P	YES	NO	YES	YES	YES	YES	YES
EUROPE	E										
KOREA	H										
AUSTRALIA	X										

RXD-M32MD-Y (X32-3810-00)

DESTINATION	COUNTRY	ABB.	UNIT No.	R22,24,37,38	C3	C4,7	C37	Q2,3	L3	W1	IC4
GENERAL MARKET	M1	0-00	YES	15P	YES	NO	YES	YES	YES	YES	YES
KOREA	H1										

RXD-M32-S/M32-LS (X32-3810-01)

DESTINATION	COUNTRY	ABB.	UNIT No.	R22,24,37,38	C3	C4,7	C37	Q2,3	L3	W1	IC4
U.S.A.	K	0-01	NO	22P	NO	YES	NO	NO	NO	NO	NO
CANADA	P										

RXD-M32-S/M32-L/M32-H/M32-W (X32-3810-01)

DESTINATION	COUNTRY	ABB.	UNIT No.	R22,24,37,38	C3	C4,7	C37	Q2,3	L3	W1	IC4
GENERAL MARKET	M	0-01	NO	22P	NO	YES	NO	NO	NO	NO	NO
AUSTRALIA	X										
U.K.	T										
EUROPE	E										
KOREA	H										

RXD-M32E-Y (X32-3810-01)

DESTINATION	COUNTRY	ABB.	UNIT No.	R22,24,37,38	C3	C4,7	C37	Q2,3	L3	W1	IC4
EUROPE	E3	0-01	NO	22P	NO	YES	NO	NO	NO	NO	NO

RXD-M32E-L/M32E-H/M32E-S/M32E-W (X32-3810-01)

DESTINATION	COUNTRY	ABB.	UNIT No.	R22,24,37,38	C3	C4,7	C37	Q2,3	L3	W1	IC4
EUROPE	E2	0-01	NO	22P	NO	YES	NO	NO	NO	NO	NO

RXD-M32-Y (X32-3810-01)

DESTINATION	COUNTRY	ABB.	UNIT No.	R22,24,37,38	C3	C4,7	C37	Q2,3	L3	W1	IC4
U.K.	T1	0-01	NO	22P	NO	YES	NO	NO	NO	NO	NO
EUROPE	E1										

RXD-SH3MD-L/SH3MD-S/SH3MD-D/SH3MD-H (3/5)
 RXD-SH3MD-Y/SH3MD-LS/SH3MD-W (3/5)
 RXD-M32MD-S/M32MD-Y/M32MD-LS/M32MD-L (3/5)
 RXD-M32-S/M32-LS/M32-L/M32-Y/M32-H/M32-W (3/5)
 RXD-M32E-L/M32E-Y/M32E-H/M32E-S/M32E-W (3/5)

CAUTION: For continued safety, replace safety critical components only with manufacturer's recommended parts (refer to parts list). Δ indicates safety critical components. For continued protection against risk of fire, replace only with same type and rating fuse(s). To reduce the risk of electric shock, leakage-current or resistance measurements shall be carried out (exposed parts are acceptably insulated from the supply circuit) before the appliance is returned to the customer.

The DC voltage is an actual reading measured with a high impedance type voltmeter with no signal input. The measurement value may vary depending on the measuring instruments used or on the product.



MDM-99D -CN1501
 MDM-99D -CN1052
 X32-CN2

AY AZ BA BB BC BD BE BF BG BH

1
 2
 3
 4
 5
 6
 7

IC101 : S-80840ANY
 IC103,111 : TA8409S
 IC104 : *
 IC105 : M62498AFP
 IC106 : HA12219NT
 IC107 : BA3126N
 IC108 : TC74HC17007AF
 IC109 : NJM4566D
 IC110 : BA05T or LM2940CT-5.0 or TA7805S or UPC7805AHF or BA17805T
 IC112 : L88M33T
 IC114 : SAA6579T/R

Q101,107 : 2SC2785(F,E) or 2SC2458(Y,GR)
 Q102,117 : 2SC2003(L,K)
 Q103 : 2SB764(E,F)
 Q104,118 : 2SA1286-T11
 Q105,106,111,112,114,119 : UN4212 or DTC124ESA
 Q108 : 2SC4081(R,S) or 2SC4116(Y,GR)
 Q109 : 2SD863(E,F)
 Q110,113 : UN4112 or DTA124ESA
 Q120 : 2SC3246

D101 : 1SS402
 D102,106,107,111,114 : 1SS133 or HSS104A
 D103,105,116 : RD5.6ES(B2) or MTZJ5.6(B)
 D108 : RD5.1ES(B2) or MTZJ5.1(B)
 D109 : RD5.6ES(B2) or MTZJ6.8(B)
 D110,115 : MA111

A101 : W02-1114-15

--- DIGITAL LINE
 --- RECORDING LINE
 --- SIGNAL LINE
 --- GND LINE
 --- +B LINE
 --- -B LINE

X14-A/6
 -E2

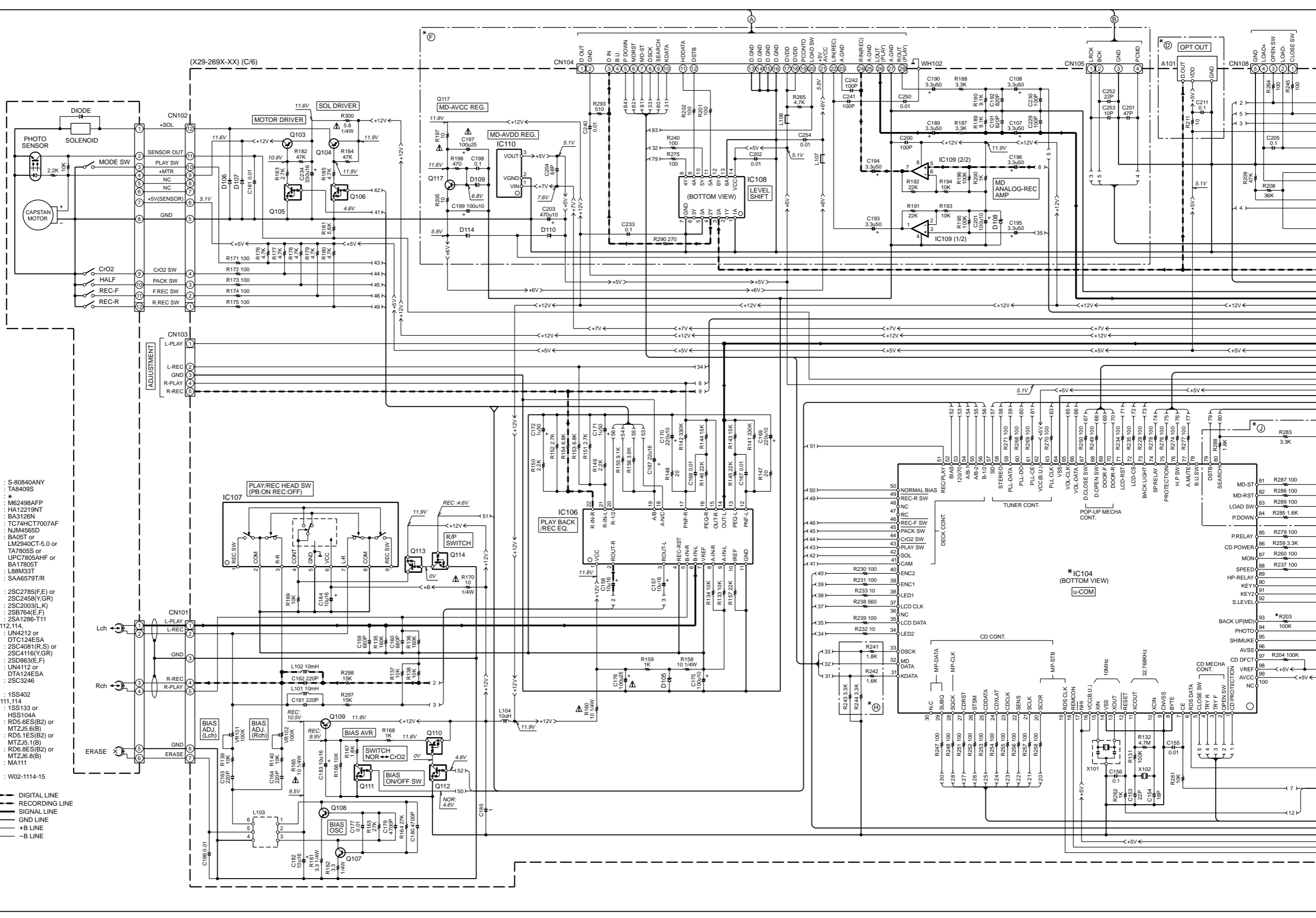

IC101 : S-80840ANY
 IC103,111 : TA8409S
 IC104 : *
 IC105 : M62498AFP
 IC106 : HA12219NT
 IC107 : BA3126N
 IC108 : TC74HC17007AF
 IC109 : NJM4566D
 IC110 : BA05T or LM2940CT-5.0 or TA7805S or UPC7805AHF or BA17805T
 IC112 : L88M33T
 IC114 : SAA6579T/R

Q101,107 : 2SC2785(F,E) or 2SC2458(Y,GR)
 Q102,117 : 2SC2003(L,K)
 Q103 : 2SB764(E,F)
 Q104,118 : 2SA1286-T11
 Q105,106,111,112,114,119 : UN4212 or DTC124ESA
 Q108 : 2SC4081(R,S) or 2SC4116(Y,GR)
 Q109 : 2SD863(E,F)
 Q110,113 : UN4112 or DTA124ESA
 Q120 : 2SC3246

D101 : 1SS402
 D102,106,107,111,114 : 1SS133 or HSS104A
 D103,105,116 : RD5.6ES(B2) or MTZJ5.6(B)
 D108 : RD5.1ES(B2) or MTZJ5.1(B)
 D109 : RD5.6ES(B2) or MTZJ6.8(B)
 D110,115 : MA111

A101 : W02-1114-15

--- DIGITAL LINE
 --- RECORDING LINE
 --- SIGNAL LINE
 --- GND LINE
 --- +B LINE
 --- -B LINE

X14-A/6
 -E2

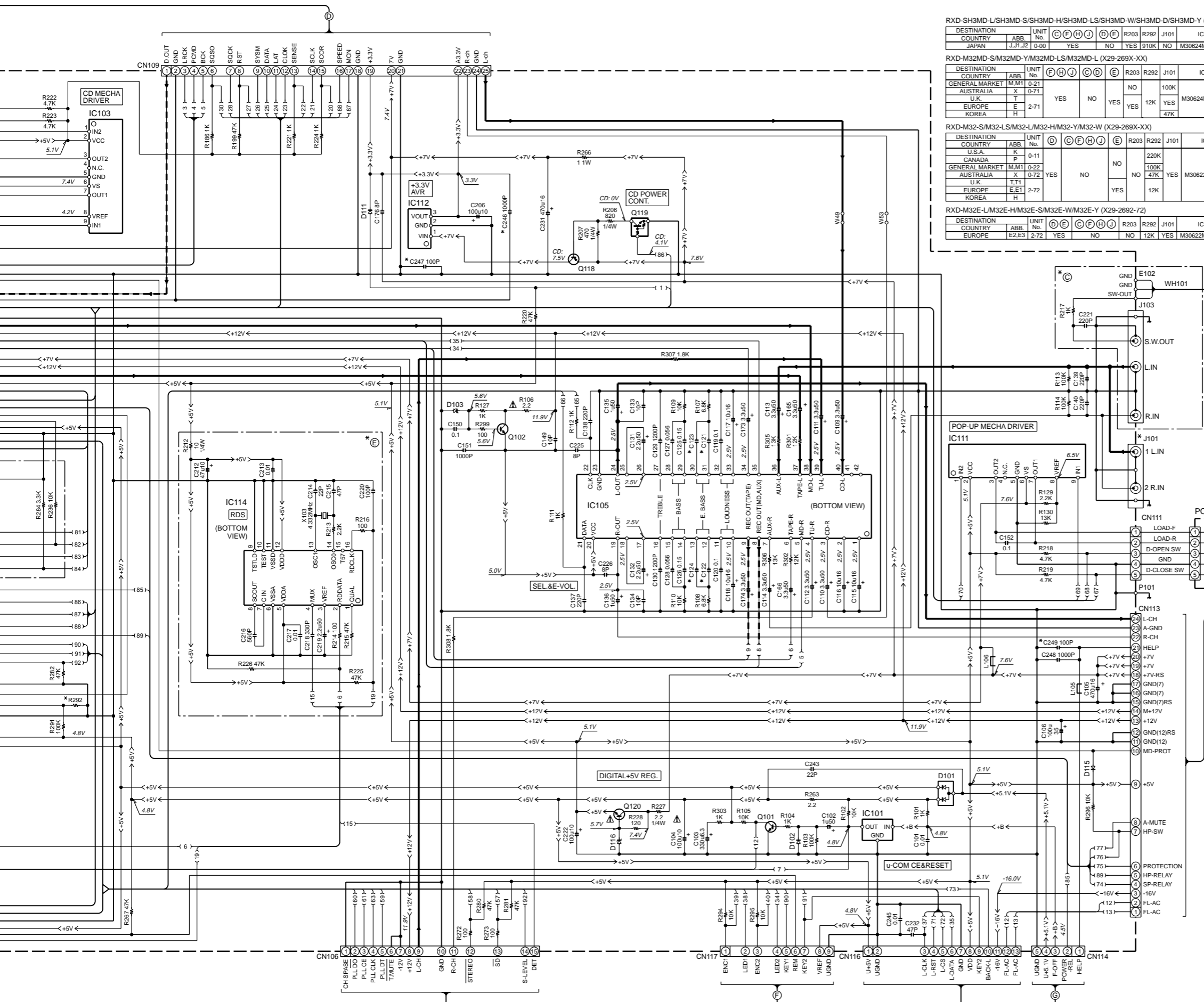

RXD-SH3MD-L/SH3MD-S/SH3MD-H/SH3MD-LS/SH3MD-W/SH3MD-D/SH3MD-Y (X29-2690-00)

DESTINATION COUNTRY	ABB.	UNIT No.	(F)	(H)	(J)	(C)	(E)	R203	R292	J101	IC104	C121, 122	C123, 124	C249	C246, 247
JAPAN	J.J1,J2	D-00	YES	NO	YES	YES	YES	12K	YES	100K	M30624MG-307FP	0.15	0.068	YES	NO

RXD-M32MD-S/M32MD-Y/M32MD-LS/M32MD-L (X29-269X-XX)

DESTINATION COUNTRY	ABB.	UNIT No.	(F)	(H)	(J)	(C)	(E)	R203	R292	J101	IC104	C121, 122	C123, 124	C249	C246, 247
GENERAL MARKET	M,M1	0-21						NO	NO	100K	M30624MG-307FP	0.15	0.068	YES	NO
AUSTRALIA	X	0-71						NO	NO	100K	M30624MG-307FP	0.15	0.068	YES	NO
U.K.	T		YES	NO	YES	YES	YES	12K	YES	100K	M30624MG-307FP	0.15	0.068	YES	NO
EUROPE	E	2-71						NO	NO	100K	M30624MG-307FP	0.15	0.068	YES	NO
KOREA	H							NO	NO	100K	M30624MG-307FP	0.15	0.068	YES	NO

RXD-M32-S/M32-LS/M32-L/M32-H/M32-Y/M32-W (X29-269X-XX)

DESTINATION COUNTRY	ABB.	UNIT No.	(F)	(H)	(J)	(C)	(E)	R203	R292	J101	IC104	C121, 122	C123, 124	C249	C246, 247
U.S.A.	K	0-11						NO	NO	220K	M30622MA-1A5FP	0.15	0.068	NO	YES
CANADA	P	0-22						NO	NO	100K	M30622MA-1A5FP	0.15	0.068	NO	YES
GENERAL MARKET	M,M1	0-22						NO	NO	100K	M30622MA-1A5FP	0.15	0.068	NO	YES
AUSTRALIA	X	0-72	YES	NO	YES	YES	YES	12K	YES	100K	M30622MA-1A5FP	0.15	0.068	NO	YES
U.K.	T,T1							NO	NO	100K	M30622MA-1A5FP	0.15	0.068	NO	YES
EUROPE	E,E1	2-72						NO	NO	100K	M30622MA-1A5FP	0.15	0.068	NO	YES
KOREA	H							NO	NO	100K	M30622MA-1A5FP	0.15	0.068	NO	YES

RXD-M32E-L/M32E-H/M32E-S/M32E-W/M32E-Y (X29-2692-72)

DESTINATION COUNTRY	ABB.	UNIT No.	(F)	(H)	(J)	(C)	(E)	R203	R292	J101	IC104	C121, 122	C123, 124	C249	C246, 247
EUROPE	E2,E3	2-72	YES	NO	NO	NO	NO	12K	YES	100K	M30622MA-1A5FP	0.15	0.068	NO	YES

CAUTION: For continued safety, replace safety critical components only with manufacturer's recommended parts (refer to parts list). Δ indicates safety critical components. For continued protection against risk of fire, replace only with same type and rating fuse(s). To reduce the risk of electric shock, leakage-current or resistance measurements shall be carried out (exposed parts are acceptably insulated from the supply circuit) before the appliance is returned to the customer.

The DC voltage is an actual reading measured with a high impedance type voltmeter with no signal input. The measurement value may vary depending on the measuring instruments used or on the product.

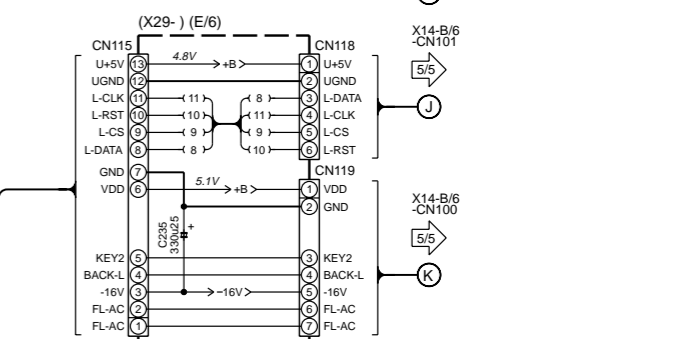

- RXD-SH3MD-L/SH3MD-S/SH3MD-D/SH3MD-H (4/5)
- RXD-SH3MD-Y/SH3MD-LS/SH3MD-W (4/5)
- RXD-M32MD-S/M32MD-Y/M32MD-LS/M32MD-L (4/5)
- RXD-M32-S/M32-LS/M32-L/M32-Y/M32-H/M32-W (4/5)
- RXD-M32E-L/M32E-H/M32E-S/M32E-W (4/5)

BS BT BU BV BW BX BY BZ CA CB

X29-C/6 -CN114 4/5 (G)

X29-C/6 -E102 4/5 (H)

X29-C/6 -CN113 4/5 (I)

X29-E/6 -CN118 4/5 (J)

X29-E/6 -CN119 4/5 (K)

X29-C/6 -CN117 4/5 (F)

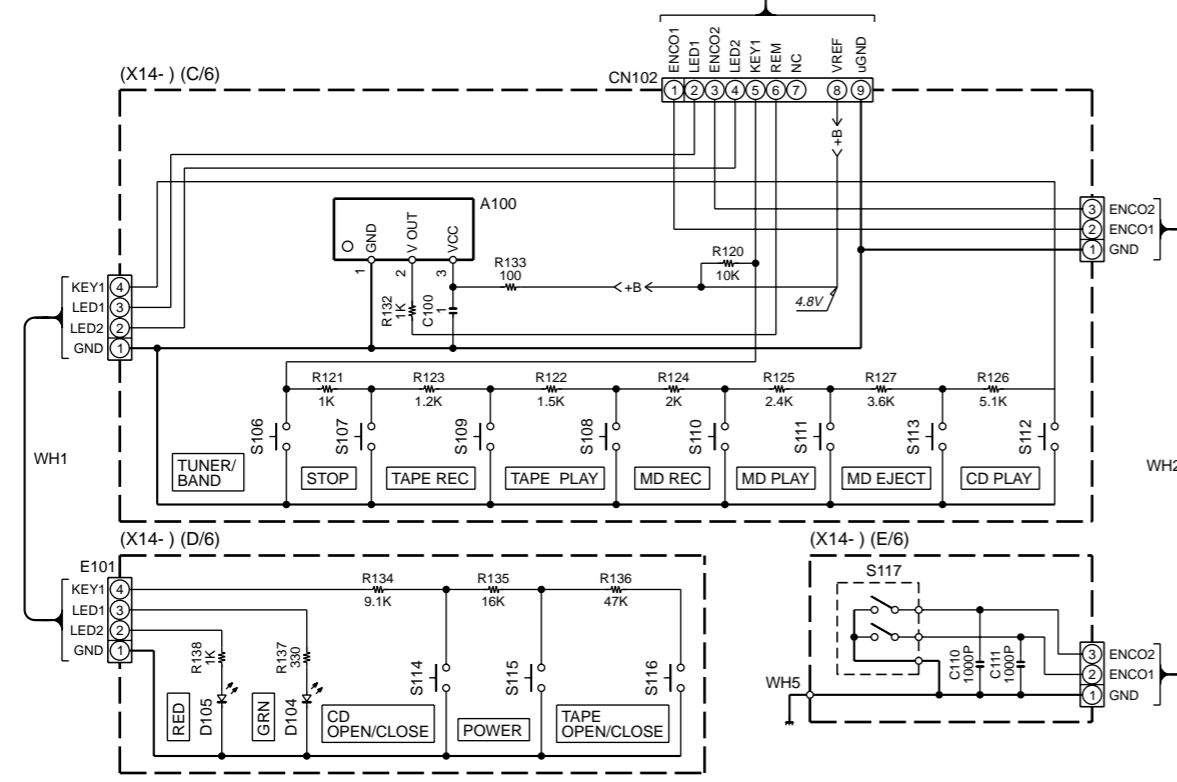
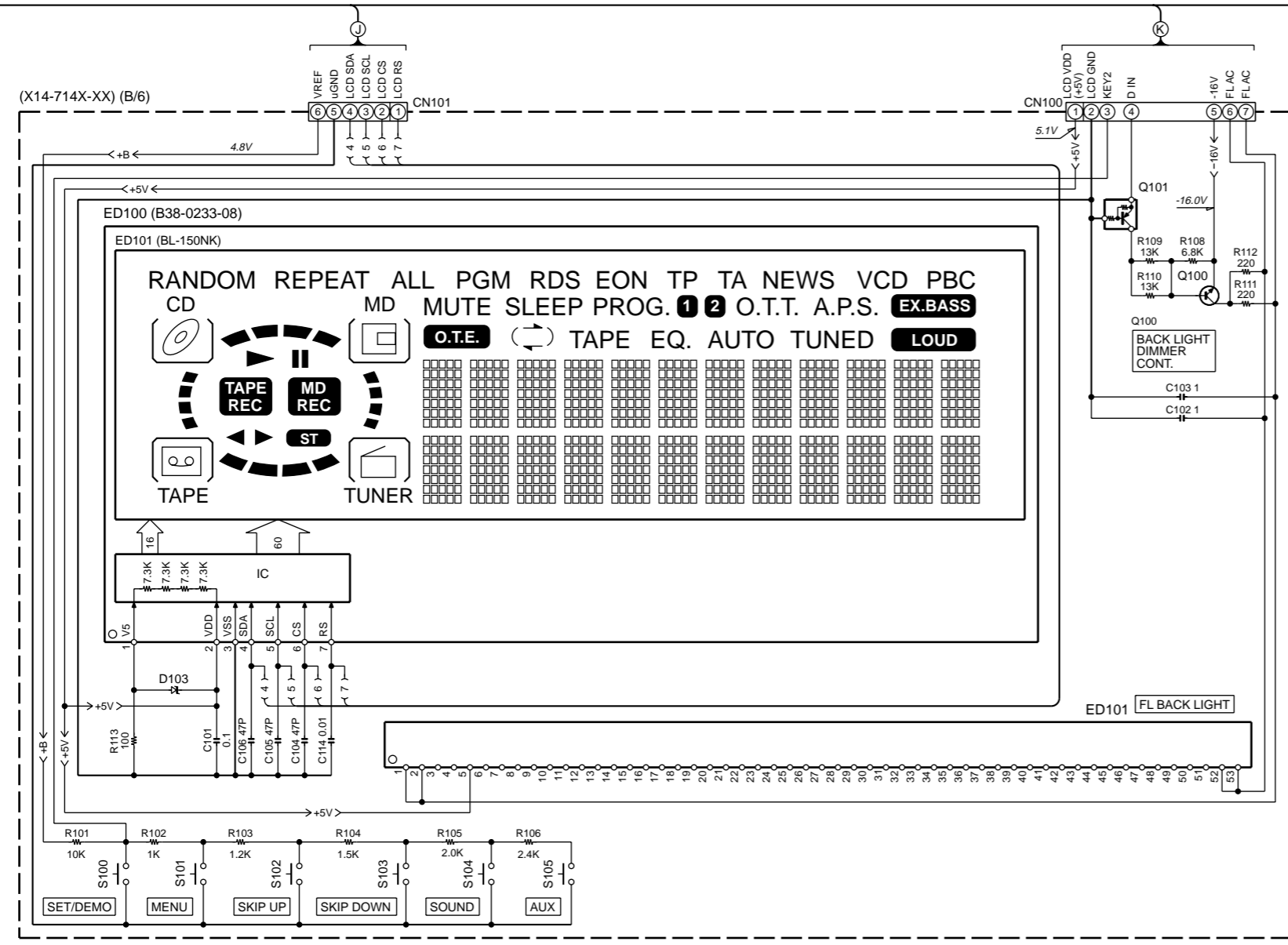

- (X14)
- Q100 : 2SD1963
 Q101 : UN5112 or DTA124EUA
- D102 : UDZ5.6B
 D103 : UDZ4.3B
 D104 : B30-2574-05
 D105 : B30-2567-05
- SIGNAL LINE
 — GND LINE
 <-+B- - +B LINE
 <-B- - -B LINE

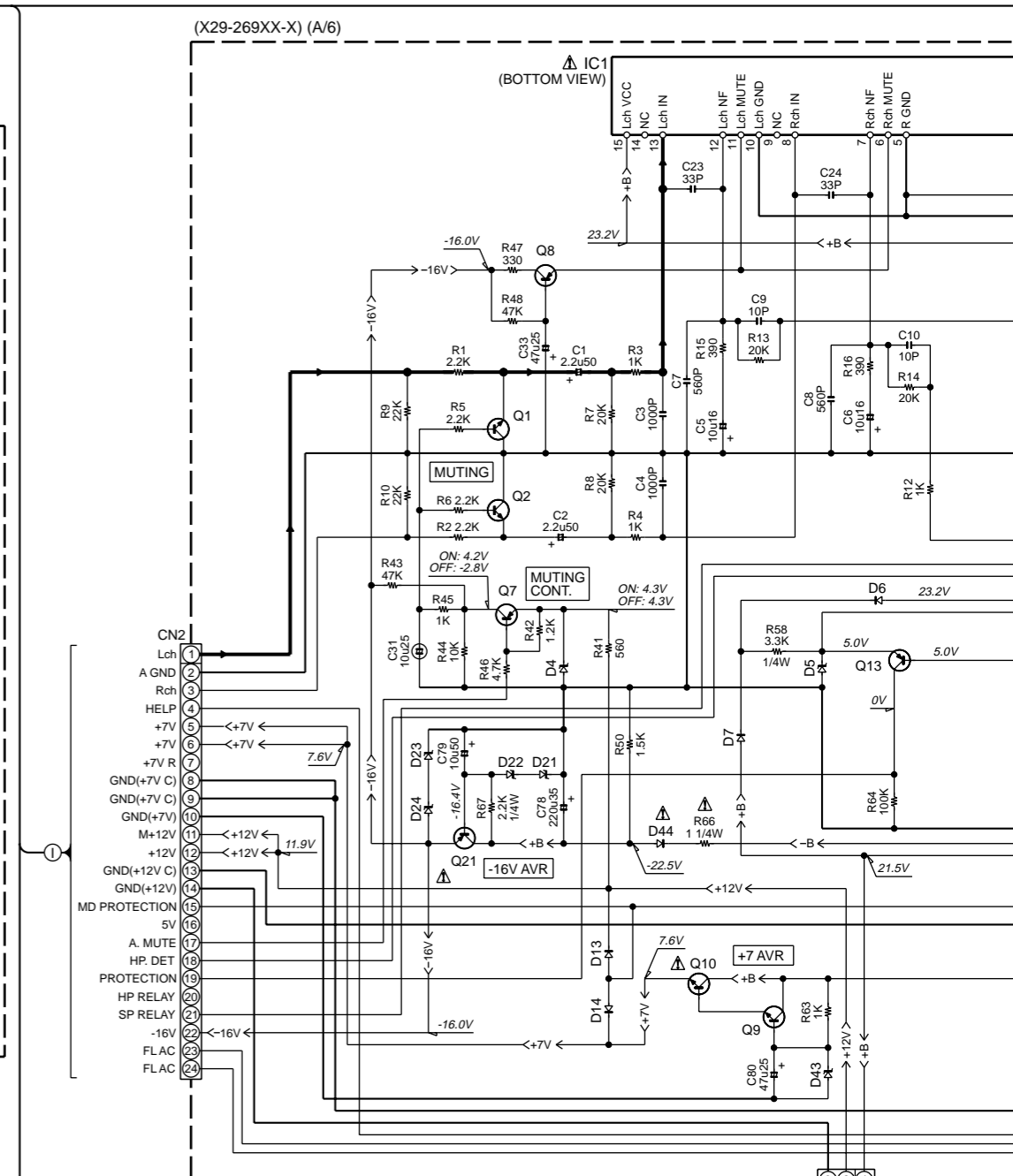

- (X29)
- IC1 : LM4766T
 IC2 : TA7812S
 IC91 : XC62HR5102P
 IC92 : NJM2930F05
- Q1,2 : 2SC2878(B)
 Q3-5,11,12,91 : 2SC2362(G,H)
 Q7 : 2SA933AS(Q,R)
 Q8,13,92 : 2SA1016(G,H)
 Q9 : 2SA4081(R,S) or 2SC4116(Y,GR)
 Q10 : 2SD2061 or 2SD2021
 Q21 : 2SB1640
- D1 : D3SBA20F03
 D2 : D2SBA20F03
 D3 : D4SBL20UF03
 D4 : RD3.9ES(B2) or MTZJ3.9(B)
 D5 : RD5.1ES(B2) or MTZJ5.1(B)
 D6,7,9-16,90,92-99 : MA111
 D8 : 1SS133 or HSS104A
 D21,23 : RD10ES(B2) or MTZJ10(B)
 D22 : RD6.8ES(B2) or MTZJ6.8(B)
 D24 : RD8.2ES(B2) or MTZJ8.2(B)
 D44 : DSK10B-AT
 D43 : RD9.1ES(B2) or MTZJ9.1(B)
 D91 : S1ZB20(4072)

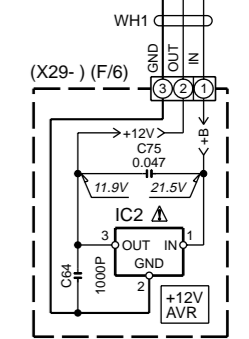

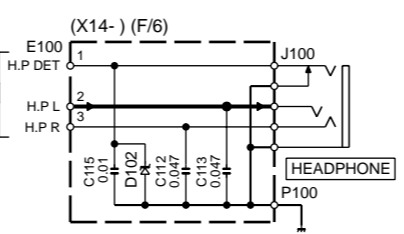
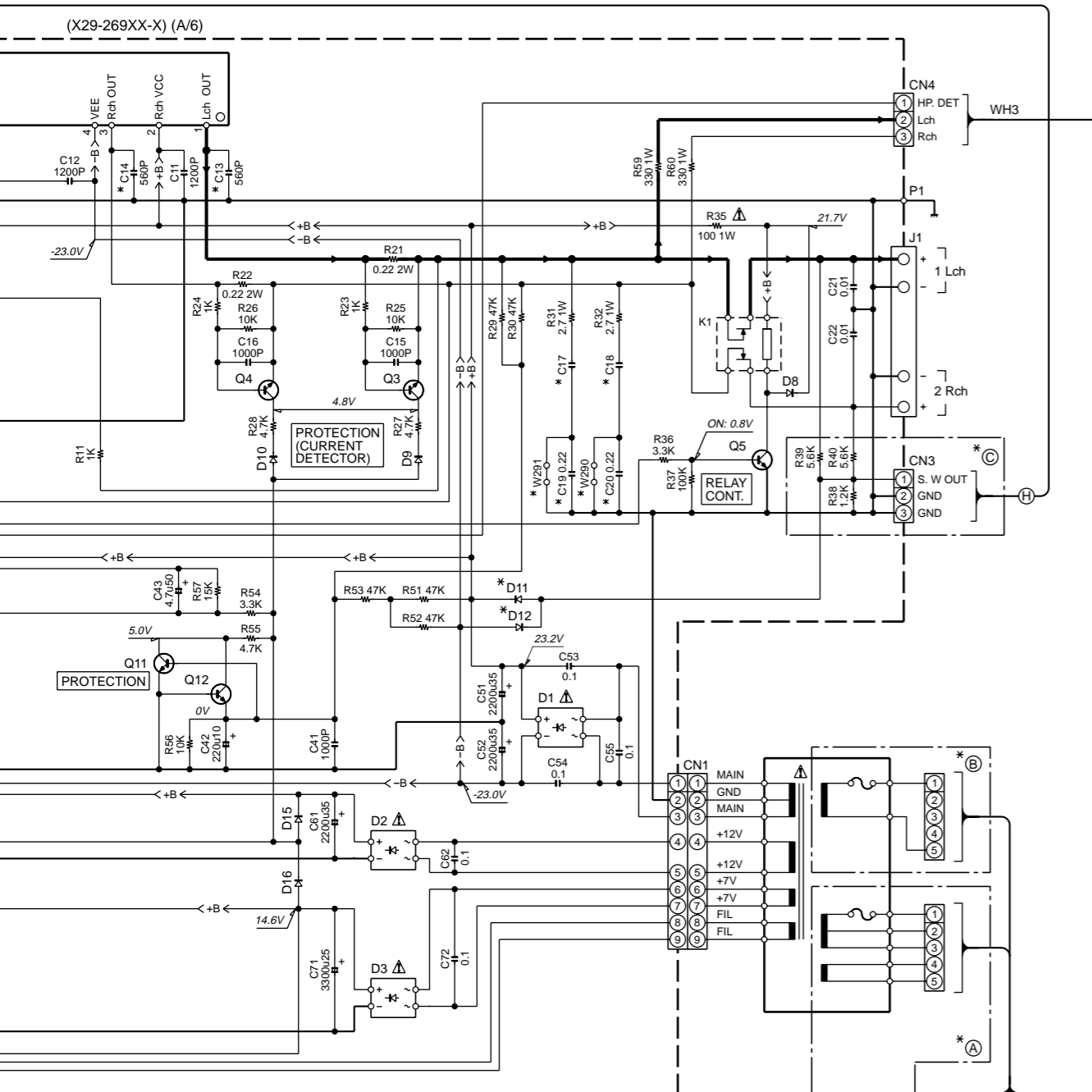

RXD-SH3MD-L/SH3MD-S/SH3MD-H/SH3MD-LS/SH3MD-W/SH3MD-D/SH3MD-Y (X29-2690-00)

DESTINATION COUNTRY	ABB.	UNIT No.	(A)	(E)	(B)	(C)	W91,265,290,291	W276	IC92	P92	D11,12,95,96	D90	R98	R100	C13,14,19,20	C17,18,93	C95	F1	F2	T91
JAPAN	J,J1,J2	0-00	NO	YES	NO	NO	YES	NO	NO	YES	YES	NO	100 1W	NO	NO	0.1	3300u16	1.6A 125V	NO	L07-2758-05

RXD-M32MD-S/M32MD-Y/M32MD-LS/M32MD-L (X29-269X-XX)

DESTINATION COUNTRY	ABB.	UNIT No.	(A)	(E)	(B)	(C)	W91,265,290,291	W276	W290,291	IC92	P92	D11,12	D90	D95,96	R98	R100	C13,14	C17,20	C93	C95	F1	F2	T91
GENERAL MARKET	M,M1	0-21	YES	NO	NO	NO	NO	YES	NO	YES	NO	NO	YES	NO	56 1W	NO	NO	0.18	3300u25	3300u16	T800mA L 250V	T800mA L 250V	L07-2758-05
AUSTRALIA	X	0-71	NO	YES	NO	NO	NO	NO	NO	NO	NO	NO	NO	YES	100 1W	NO	560P	0.22	0.1	3300u16	T800mA L 250V	NO	L07-2897-08
U.K.	T		NO	YES	NO	NO	YES	NO	NO	NO	YES	NO	NO	YES	100 1W	NO	560P	0.22	0.1	3300u16	T800mA L 250V	NO	L07-2897-08
EUROPE	E	2-71	NO	YES	NO	NO	YES	NO	NO	NO	YES	NO	NO	YES	100 1W	NO	560P	0.22	0.1	3300u16	T800mA L 250V	NO	L07-2897-08
KOREA	H,H1		NO	YES	NO	NO	YES	NO	NO	NO	YES	NO	NO	YES	100 1W	NO	560P	0.22	0.1	3300u16	T800mA L 250V	NO	L07-2897-08

RXD-M32-S/M32-LS/M32-L/M32-H/M32-Y/M32-W (X29-269X-XX)

DESTINATION COUNTRY	ABB.	UNIT No.	(A)	(E)	(B)	(C)	W91,265,290,291	W276	W290,291	IC92	P92	D11,12	D90	D95,96	R98	R100	C13,14	C17,18	C19,20	C93	C95	F1	F2	T91
U.S.A.	K	0-11	NO	YES	NO	NO	YES	NO	YES	NO	YES	NO	NO	YES	100 1W	YES	NO	0.1	NO	0.1	3300u16	1.6A 125V	NO	L07-2758-05
CANADA	P		NO	YES	NO	NO	YES	NO	NO	YES	NO	NO	NO	YES	100 1W	NO	NO	0.1	NO	0.1	3300u25	T800mA L 250V	NO	L07-2758-05
GENERAL MARKET	M,M1	0-22	YES	NO	NO	NO	NO	YES	NO	NO	NO	NO	NO	YES	56 1W	NO	NO	0.18	3300u25	3300u16	T800mA L 250V	T800mA L 250V	L07-2758-05	
AUSTRALIA	X	0-72	NO	YES	NO	NO	NO	NO	NO	NO	NO	NO	NO	YES	100 1W	NO	560P	0.22	0.1	3300u16	T800mA L 250V	NO	L07-2897-08	
U.K.	T,T1		NO	YES	NO	NO	YES	NO	NO	NO	YES	NO	NO	YES	100 1W	NO	560P	0.22	0.1	3300u16	T800mA L 250V	NO	L07-2897-08	
EUROPE	E,E1	2-72	NO	YES	NO	NO	YES	NO	NO	NO	YES	NO	NO	YES	100 1W	NO	560P	0.22	0.1	3300u16	T800mA L 250V	NO	L07-2897-08	
KOREA	H		NO	YES	NO	NO	YES	NO	NO	NO	YES	NO	NO	YES	100 1W	NO	560P	0.22	0.1	3300u16	T800mA L 250V	NO	L07-2897-08	

RXD-M32E-L/M32E-H/M32E-S/M32E-W/M32E-Y (X29-2692-72)

DESTINATION COUNTRY	ABB.	UNIT No.	(A)	(E)	(B)	(C)	W91,265,290,291	W276	IC92	P92	D11,12,90	D95,96	R98	R100	C13,14	C17,20	C93	C95	F1	F2	T91
EUROPE	E2,E3	2-72	NO	YES	NO	NO	YES	NO	NO	YES	NO	YES	100 1W	NO	560P	0.22	0.1	3300u16	T800mA L 250V	NO	L07-2897-08

CAUTION: For continued safety, replace safety critical components only with manufacturer's recommended parts (refer to parts list). Δ indicates safety critical components. For continued protection against risk of fire, replace only with same type and rating fuse(s). To reduce the risk of electric shock, leakage-current or resistance measurements shall be carried out (exposed parts are acceptably insulated from the supply circuit) before the appliance is returned to the customer.

The DC voltage is an actual reading measured with a high impedance type voltmeter with no signal input. The measurement value may vary depending on the measuring instruments used or on the product.

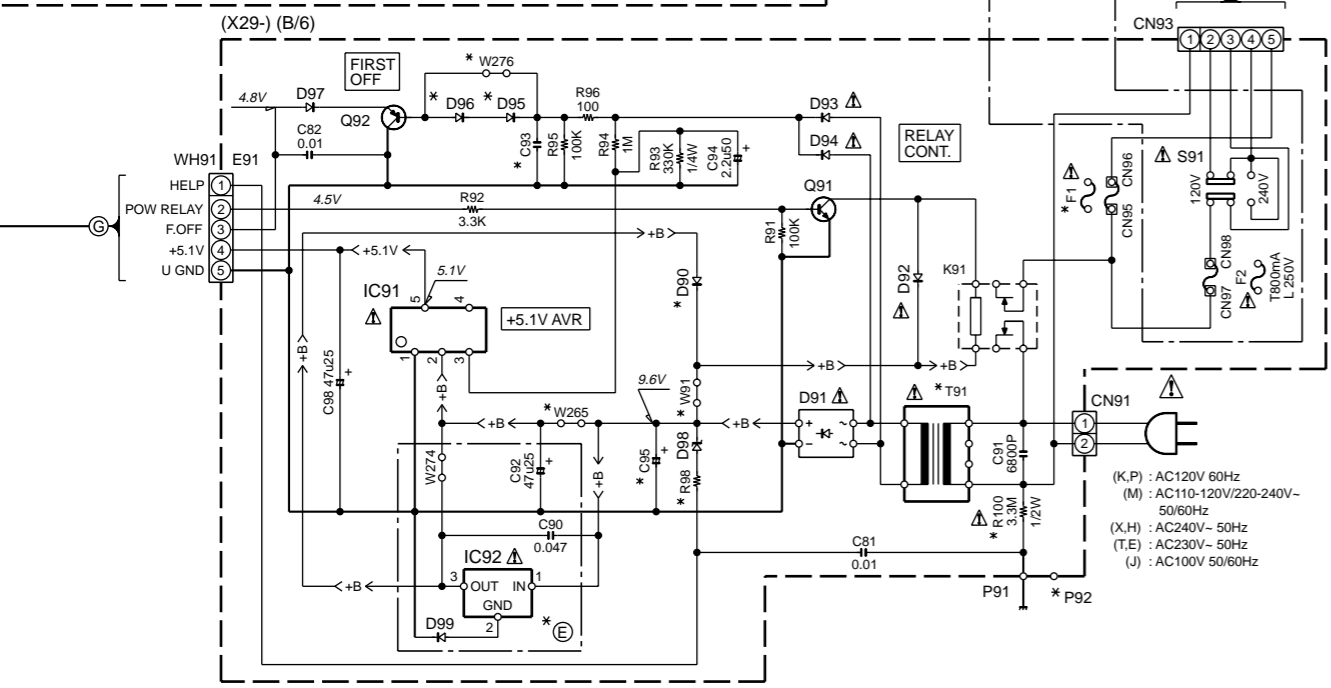

RXD-SH3MD-L/SH3MD-S/SH3MD-H/SH3MD-LS/SH3MD-W (5/5)
 RXD-M32MD-S/M32MD-Y/M32MD-LS/M32MD-L (5/5)
 RXD-M32-S/M32-LS/M32-L/M32-Y/M32-H/M32-W (5/5)
 RXD-M32E-L/M32E-Y/M32E-H/M32E-S/M32E-W (5/5)

Y39-3520-21

RXD-M32MD
KENWOOD

RXD-M32MD

EXPLODED VIEW (CD MECHANISM)

- AA WASHER HEAD : N09-1522-05
- AB ϕ 2.6x16 : N09-3345-08
- AC M2x3 : N30-2003-46
- AD M2.6x4 (BLK) : N35-2604-45
- AE ϕ 3x8 : N87-3008-46
- AF ϕ 3x10 : N87-3010-46
- AG ϕ 2.6x6 (BLK) : N88-2606-45

1

2

3

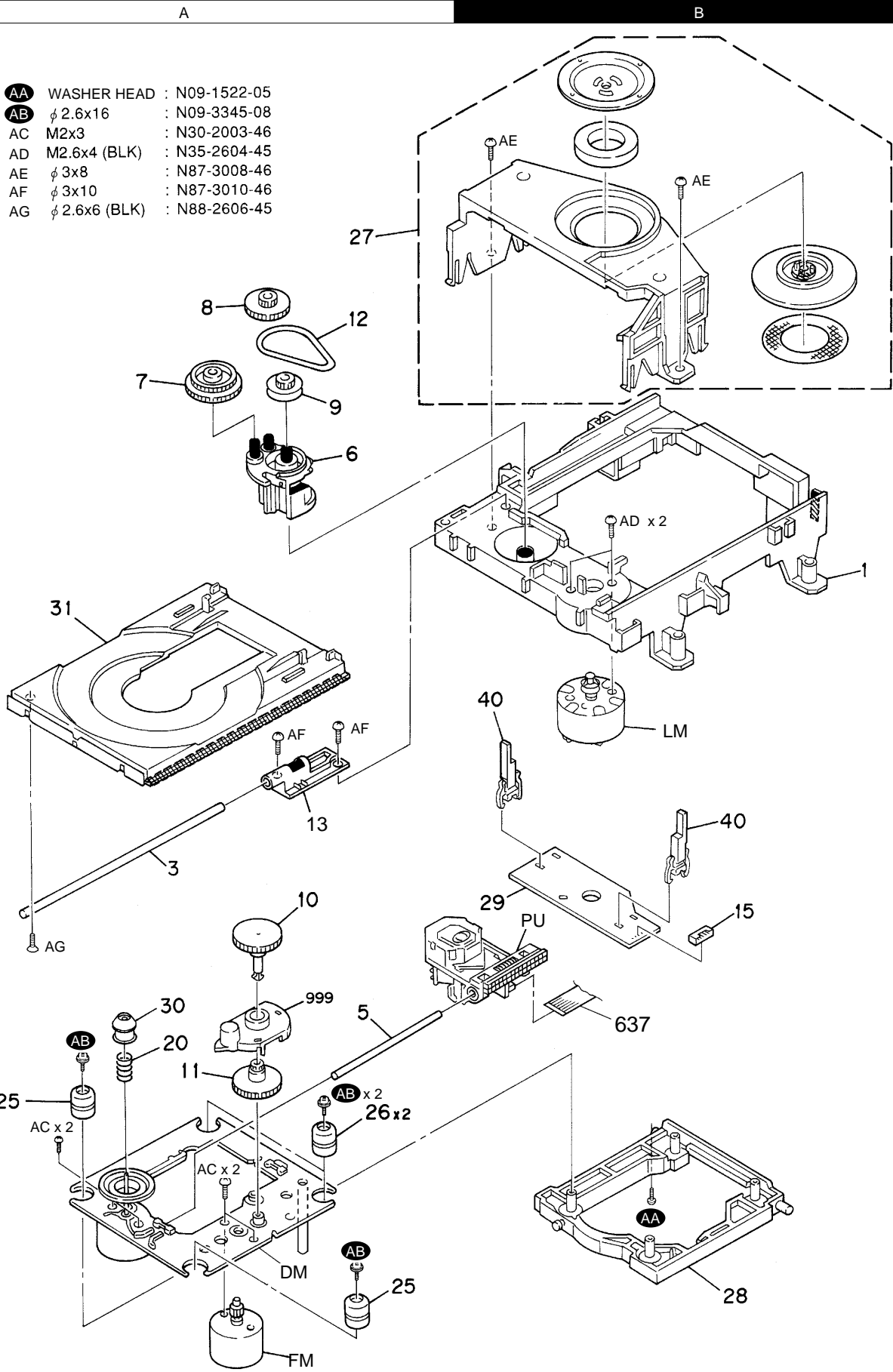

Parts with exploded numbers larger than 700 are not supplied.

RXD-M32MD

EXPLODED VIEW (MD MECHANISM)

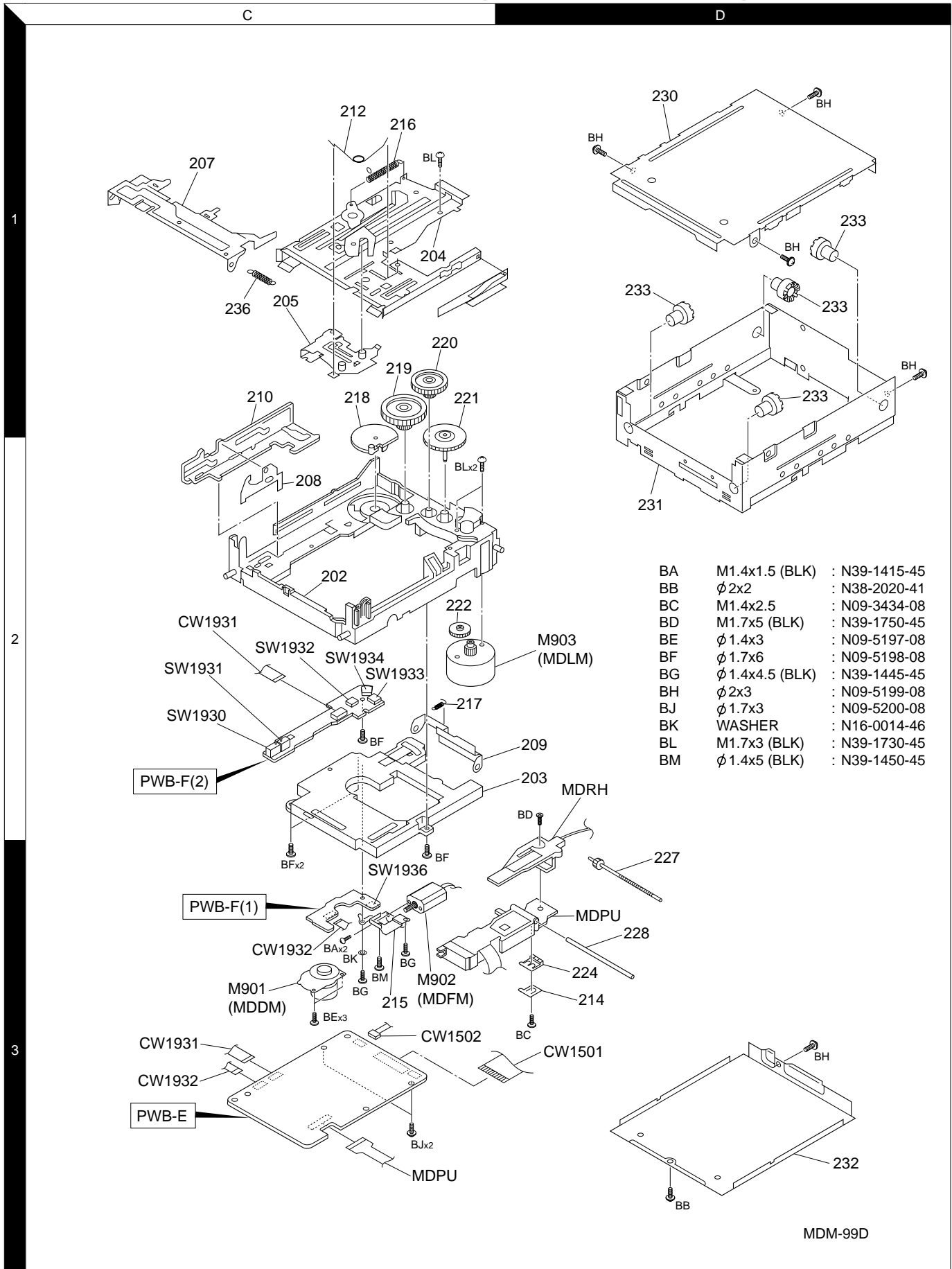

2

3

Parts with exploded numbers larger than 700 are not supplied.

EXPLODED VIEW (UNIT)

RXD-M32MD

Parts with exploded numbers larger than 700 are not supplied.

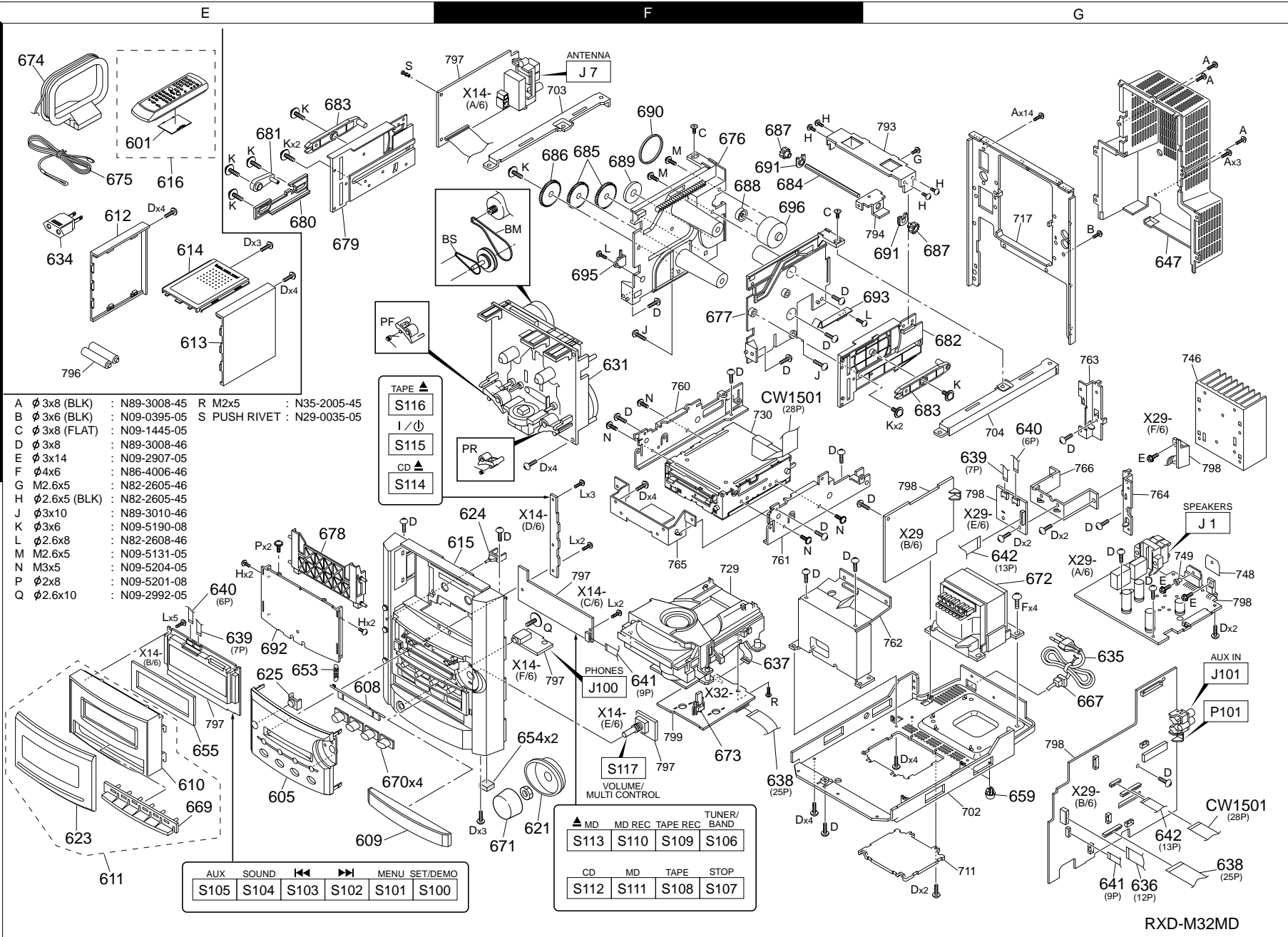

- A ϕ 3x8 (BLK) : N89-3008-45 R M2x5 : N35-2005-45
- B ϕ 3x6 (BLK) : N09-0395-05 S PUSH RIVET : N29-0035-05
- C ϕ 3x8 (FLAT) : N09-1445-05
- D ϕ 3x8 : N89-3008-46
- E ϕ 3x14 : N09-2907-05
- F ϕ 4x6 : N86-4006-46
- G M2.6x5 : N82-2605-46
- H ϕ 2.6x5 (BLK) : N82-2605-45
- J ϕ 3x10 : N89-3010-46
- K ϕ 3x6 : N09-5190-08
- L ϕ 2.6x8 : N82-2608-46
- M M2.6x5 : N09-5131-05
- N M3x5 : N09-5204-05
- P ϕ 2x8 : N09-5201-08
- Q ϕ 2.6x10 : N09-2992-05

TAPE	▲
S116	
I / ϕ	
S115	
CD	▲
S114	

▲ MD	MD REC	TAPE REC	TUNER/ BAND
S113	S110	S109	S106
CD	MD	TAPE	STOP
S112	S111	S108	S107

AUX	SOUND	⏮	⏭	MENU SET/DEMO
S105	S104	S103	S102	S101

RXD-M32MD

* New Parts
 Parts without **Parts No.** are not supplied.
 Les articles non mentionnés dans le **Parts No.** ne sont pas fournis.
 Teile ohne **Parts No.** werden nicht geliefert.

①

Ref. No	Add-ress	New Parts	Parts No.	Description	Desti-nation	Re-marks
RXD-M32MD						
601	1E	*	A09-1161-08	BATTERY COVER SURVICE		
605	2E	*	A21-3843-08	DRESSING PANEL CENTER MD	MX	
605	2E	*	A21-3844-08	DRESSING PANEL CENTER MD	TEH	
608	2E	*	A29-1097-08	PANEL MD		
609	2E	*	A29-1099-08	PANEL CD		
610	2E	*	A29-1101-08	PANEL LID		
611	2E	*	A29-1121-08	PANEL ASSY LID		
612	1E	*	A50-1354-08	SIDE PLATE L,BLUE	MXH	L
612	1E	*	A50-1355-08	SIDE PLATE L,SILVER	MTEH	S
612	1E	*	A50-1358-08	SIDE PLATE L,YELLOW-S	M1H1	Y
612	1E	*	A50-1359-08	SIDE PLATE L,BLUE-S	MXH	LS
613	1E	*	A50-1361-08	SIDE PLATE R,BLUE	MXH	LS
613	1E	*	A50-1362-08	SIDE PLATE R,SILVER	MTEH	LS
613	1E	*	A50-1365-08	SIDE PLATE R,YELLOW-S	M1H1	Y
613	1E	*	A50-1366-08	SIDE PLATE R,BLUE-S	MXH	LS
614	1E	*	A52-0387-08	TOP PLATE		
615	2F	*	A60-1909-08	PANEL ASSY BLUE	MXH	L
615	2F	*	A60-1914-08	PANEL ASSY BLUE-S	MXH	LS
615	2F	*	A60-1910-08	PANEL ASSY SILVER	MTEH	S
615	2F	*	A60-1913-08	PANEL ASSY YELLOW-S	M1H1	Y
616	1E	*	A70-1375-08	REMOTE CONTROL ASSY WHITE	M	S
616	1E	*	A70-1376-08	REMOTE CONTROL ASSY 43,WHITE	TEH	
616	1E	*	A70-1393-08	REMOTE CONTROL ASSY YELLOW	M1	Y
616	1E	*	A70-1416-08	REMOTE CONTROL ASSY BLUE	MX	L
616	1E	*	A70-1416-08	REMOTE CONTROL ASSY BLUE	MX	LS
621	2F	*	B07-2517-08	ESCUTCHEON		
623	2E	*	B10-3591-08	FRONT GLASS DECK		
624	2F	*	B12-0396-08	INDICATOR POWER		
625	2E	*	B12-0397-08	INDICATOR REMOCON		
-			B46-0096-53	WARRANTY CARD	X	
-			B46-0310-03	WARRANTY CARD	ET	
-			B46-0350-00	QUESTIONAIRE CARD	T	
-			B58-0965-13	CAUTION CARD	XT	
-			B58-0966-13	CAUTION CARD	ME	
-		*	B60-4719-08	INSTRUCTION MANUAL (EN)	MXT	
-		*	B60-4720-08	INSTRUCTION MANUAL (TC)	M	
-		*	B60-4721-08	INSTRUCTION MANUAL (FR)	E	
-		*	B60-4722-08	INSTRUCTION MANUAL (GE)	E	
-		*	B60-4723-08	INSTRUCTION MANUAL (NE)	E	
-		*	B60-4724-08	INSTRUCTION MANUAL (IT)	E	
-		*	B60-4725-08	INSTRUCTION MANUAL (ES)	E	
631	1F	*	D40-1681-05	MECHANISM ASSY DECK,VOLTEX		
BM	1F		D16-0741-08	BELT(MAIN)		
BS	1F		D16-0705-08	BELT(SUB)		
PF	1F		D14-0380-08	PINCH ROLLER(FWD)		
PR	1F		D14-0381-08	PINCH ROLLER(RVS)		
△ 634	1E		E03-0115-05	AC PLUG ADAPTER	M	
△ 635	2G		E30-2592-15	AC CORD	ME	
△ 635	2G		E30-2717-05	AC CORD	X	
△ 635	2G		E30-2721-05	AC CORD	T	
△ 635	2G		E30-2845-05	AC CORD	H	
636	2G	*	E35-2576-08	FLAT CABLE DECK12PFFC		
637	2F	*	E35-2578-08	FLAT CABLE CD16PFFC		

L: Scandinavia K: USA P: Canada R: Mexico C: China I: Malaysia
 Y: PX(Far East,Hawaii) T: England E: Europe G: Germany V: China(Shanghai)
 Y: AAFES(Europe) X: Australia Q: Russia H: Korea M: Other Areas △ indicates safety critical components.

* New Parts
 Parts without **Parts No.** are not supplied.
 Les articles non mentionnés dans le **Parts No.** ne sont pas fournis.
 Teile ohne **Parts No.** werden nicht geliefert.

②

Ref. No	Add-ress	New Parts	Parts No.	Description	Desti-nation	Re-marks
638	2G	*	E35-2579-08	FLAT CABLE CD25PFFC		
639	1G,2E	*	E35-2581-08	FLAT CABLE LCD7PFFC/7P		
640	1G,2E	*	E35-2582-08	FLAT CABLE LCD7PFFC/6P		
641	2F,2G	*	E35-2583-08	FLAT CABLE X14-X29,9P		
642	2G	*	E35-2637-08	FLAT CABLE SHIELD/FFC		
-		*	E35-2577-08	WIRING HARNESS DECK HEADLEAD		
647	1G	*	F07-1704-08	COVER	XTEH	
647	1G	*	F07-1705-08	COVER	M	
-		*	F29-0127-08	INSULATING TUBE (AC CORD)		
653	2E	*	G01-4198-08	EXTENSION SPRING MD		
654	2F	*	G11-2342-08	CUSHION FOOT		
655	2E	*	G11-2734-08	SOFT TAPE FORLCD		
-		*	H10-7669-08	POLYSTYRENE FOAMED FIXTURE L		
-		*	H10-7670-08	POLYSTYRENE FOAMED FIXTURE R		
-		*	H25-0232-04	PROTECTION BAG ACCESSORY	MXEH	
-		*	H25-0651-04	PROTECTION BAG ACCESSORY	T	
-		*	H25-0661-04	PROTECTION BAG SET	M	
-		*	H25-1516-04	PROTECTION BAG SET	X	
-		*	H25-1561-04	PROTECTION BAG SET	TEH	
-		*	H50-3685-08	ITEM CARTON CASE 1PACKAGE	MH	S
-		*	H50-3686-08	ITEM CARTON CASE 1PACKAGE	M1H1	Y
-		*	H50-3687-08	ITEM CARTON CASE 1PACKAGE	MH	LS
-		*	H50-3689-08	ITEM CARTON CASE SEP	TE	S
-		*	H50-3795-08	ITEM CARTON CASE 1PACKAGE	X	LS
-		*	H50-3875-08	ITEM CARTON CASE BLUE/M	MH	LL
-		*	H50-3876-08	ITEM CARTON CASE BLUE/X	X	L
659	2G		J02-0370-05	FOOT		
△ 667	2G		J42-0083-05	POWER CORD BUSHING		
-			J61-0307-05	WIRE BAND		
669	2E	*	K29-7780-08	KNOB		
670	2E	*	K29-7782-08	KNOB PPB5-6	MHTE	S
670	2E	*	K29-7782-08	KNOB PPB5-6	MXH	LS
670	2E	*	K29-7782-08	KNOB PPB5-6	MXH	LS
670	2E	*	K29-7785-08	KNOB PY8-2	M1H1	Y
671	2F	*	K29-7789-08	KNOB		
△ 672	2G	*	L07-2868-08	POWER TRANSFORMER	M	
△ 672	2G	*	L07-2869-08	POWER TRANSFORMER	TEH	
△ 672	2G	*	L07-2870-08	POWER TRANSFORMER	X	
P		*	N09-5201-08	TAPTITE SCREW A29(DECK)		
673	2F		S74-0065-05	LEAF SWITCH		
674	1E		T90-0852-05	LOOP ANTENNA		
675	1E	*	T90-0861-05	LEAD WIRE ANTENNA		
676	1F	*	A10-3515-08	CHASSIS		
677	1F	*	A10-3516-08	CHASSIS		
678	2E	*	A53-2194-08	CASSETTE HOLDER		
679	1E	*	D10-3934-08	SLIDER		
680	1E	*	D10-3935-08	SLIDER		
681	1E	*	D10-3936-08	ARM		
682	1G	*	D10-3937-08	SLIDER		
683	1E	*	D10-3938-08	ARM		

L: Scandinavia K: USA P: Canada R: Mexico C: China I: Malaysia
 Y: PX(Far East,Hawaii) T: England E: Europe G: Germany V: China(Shanghai)
 Y: AAFES(Europe) X: Australia Q: Russia H: Korea M: Other Areas △ indicates safety critical components.

* New Parts

Parts without **Parts No.** are not supplied.
 Les articles non mentionnés dans le **Parts No.** ne sont pas fournis.
 Teile ohne **Parts No.** werden nicht geliefert.

③

Ref. No	Add-ress	New Parts	Parts No.	Description	Desti-nation	Re-marks
684	1F	*	D10-3940-08	ROD		
685	1F	*	D13-1989-08	GEAR		
686	1F	*	D13-1990-08	GEAR		
687	1G	*	D13-1991-08	GEAR		
688	1F	*	D15-0430-08	PULLEY		
689	1F	*	D15-0431-08	PULLEY		
690	1F	*	D16-0747-08	BELT		
691	1G	*	D23-0337-08	RETAINER		
692	2E	*	J19-6073-08	HOLDER		
693	1G	*	G02-1712-08	FLAT SPRING		
695	1F	*	S64-0026-05	LEVER SWITCH		
696	1F	*	T42-0955-05	DC MOTOR		
D			N89-3008-46	BINDING HEAD TAPTITE SCREW		
G			N86-2605-46	BINDING HEAD TAPTITE SCREW		
H			N82-2605-45	BINDING HEAD TAPTITE SCREW		
K			N09-5190-08	SET SCREW		
L			N82-2608-46	BINDING HEAD TAPTITE SCREW		
M			N09-5131-05	MACHINE SCREW		
DISPLAY UNIT (X14-714X-XX)						
D104			B11-1509-08	COLOR FILTER (BLUE)	MTEHX	
D105			B11-1510-08	COLOR FILTER (YELLOW)	M1H1	
ED100			B30-2574-05	LED(GRN3(80))		
			B30-2567-05	LED(RED(80) HI-BR)		
			B38-0233-08	LCD DISPLAY ASSY		
C1			CK73FB1H223K	CHIP C 0.022UF	K	
C2			CK73FB1H103K	CHIP C 0.010UF	K	TEHH1
C3			CK73FB1H103K	CHIP C 0.010UF	K	
C5 ,6			CK73FB1H103K	CHIP C 0.010UF	K	
C7			CE04LW1C470M	ELECTRO 47UF	16VV	
C10			CE04LW1C470M	ELECTRO 47UF	16VV	
C11 ,12			CK73FB1H473K	CHIP C 0.047UF	K	
C14			CE04LW1C100M	ELECTRO 10UF	16VV	
C15			CE04LW1H010M	ELECTRO 1.0UF	50VV	
C16			CE04RW1HR47M	ELECTRO 0.47UF	50VV	
C17			CE04LW1H010M	ELECTRO 1.0UF	50VV	
C18			CC73FCH1H470J	CHIP C 47PF	J	
C19			CE04RW1A100M	ELECTRO 10UF	10VV	
C20			CK73FB1H473K	CHIP C 0.047UF	K	
C21			CE04RW1V3R3M	ELECTRO 3.3UF	35VV	
C22			CK73FB1H473K	CHIP C 0.047UF	K	
C23			CE04LW1C100M	ELECTRO 10UF	16VV	
C24			CK73FB1H331K	CHIP C 330PF	K	
C25			CC73FCH1H181J	CHIP C 180PF	J	TEHH1
C25			CC73FCH1H471J	CHIP C 470PF	J	MM1X
C26			CK73FB1H183K	CHIP C 0.018UF	K	TEHH1
C26			CK73FB1H223K	CHIP C 0.022UF	K	MM1X
C27			CE04HW1E4R7M	NP-ELEC 4.7UF	25VV	
C28 ,29			CE04LW1H2R2M	ELECTRO 2.2UF	50VV	
C30 ,31			CK73FB1H223K	CHIP C 0.022UF	K	
C32			CE04LW1V4R7M	ELECTRO 4.7UF	35VV	
C33 ,34			CK73FB1H103K	CHIP C 0.010UF	K	MM1
C35			CK73FB1H332K	CHIP C 3300PF	K	MM1X
C36			CK73FB1H103K	CHIP C 0.010UF	K	
C37 ,38			CE04LW1C100M	ELECTRO 10UF	16VV	

L : Scandinavia K : USA P : Canada R : Mexico C : China I : Malaysia
 Y : PX(Far East,Hawaii) T : England E : Europe G : Germany V : China(Shanghai)
 Y : AAFES(Europe) X : Australia Q : Russia H : Korea M : Other Areas Δ indicates safety critical components.

* New Parts

Parts without **Parts No.** are not supplied.
 Les articles non mentionnés dans le **Parts No.** ne sont pas fournis.
 Teile ohne **Parts No.** werden nicht geliefert.

④

Ref. No	Add-ress	New Parts	Parts No.	Description	Desti-nation	Re-marks
C41			CC73FCH1H470J	CHIP C 47PF	J	
C42			CC73FCH1H120J	CHIP C 12PF	J	
C43			CC73FCH1H100D	CHIP C 10PF	D	
C44			CK73FB1H471K	CHIP C 470PF	K	
C45			CC73FCH1H220J	CHIP C 22PF	J	
C46			CE04LW1C100M	ELECTRO 10UF	16VV	
C47			CK73FB1H102K	CHIP C 1000PF	K	
C48			CE04LW1C470M	ELECTRO 47UF	16VV	
C49			CE04LW1H2R2M	ELECTRO 2.2UF	50VV	
C50			CC73FSL1H101J	CHIP C 100PF	J	
C51			CK73FB1H471K	CHIP C 470PF	K	
C52			CC73FSL1H101J	CHIP C 100PF	J	
C70 ,71			CK73FB1H682K	CHIP C 6800PF	K	TEHH1
C72			CE04LW1H010M	ELECTRO 1.0UF	50VV	
C73			CE04LW1C470M	ELECTRO 47UF	16VV	
C75			CC73FCH1H030C	CHIP C 3.0PF	C	
C76			CC73FCH1H470J	CHIP C 47PF	J	
C78			CK73FB1H223K	CHIP C 0.022UF	K	
C79 ,80			CK73FB1H332K	CHIP C 3300PF	K	MM1X
C79 ,80			CK73FB1H682K	CHIP C 6800PF	K	TEHH1
C81			CK73FF1C105Z	CHIP C 1.0UF	Z	
C82			CK73FB1H103K	CHIP C 0.010UF	K	TEHH1
C83			CC73FSL1H101J	CHIP C 100PF	J	TEHH1
C83			CK73FB1H223K	CHIP C 0.022UF	K	MM1X
C84 ,85			CK73FB1H223K	CHIP C 0.022UF	K	
C86			CK73FB1H471K	CHIP C 470PF	K	
C88			CK73FB1H332K	CHIP C 3300PF	K	
C89 ,90			CK73FB1H472K	CHIP C 4700PF	K	MM1X
C91			CK73FF1C105Z	CHIP C 1.0UF	Z	
C100			CK73EF1C105Z	CHIP C 1.0UF	Z	
C101			CK73GB1C104K	CHIP C 0.10UF	K	
C102,103			CK73EF1C105Z	CHIP C 1.0UF	Z	
C104-106			CC73GCH1H470J	CHIP C 47PF	J	
C110,111			CK73GB1H102K	CHIP C 1000PF	K	
C112,113			CK73GB1C473K	CHIP C 0.047UF	K	
C114,115			CK73GB1H103K	CHIP C 0.010UF	K	
CN4			E40-4871-05	PIN ASSY		TEHH1
CN100		*	E40-8613-05	FLAT CABLE CONNECTOR		
CN101		*	E40-8635-05	FLAT CABLE CONNECTOR		
CN102		*	E40-8612-05	FLAT CABLE CONNECTOR		
J7			E20-0321-05	LOCK TERMINAL BOARD		
J7			E70-0052-05	LOCK TERMINAL BOARD		
J100			E11-0200-05	MINIATURE PHONE JACK(5P)		
E1		*	F10-1165-08	SHIELDING PLATE		MM1X
E1		*	F10-1166-08	SHIELDING PLATE		TEHH1
-		*	G11-2733-08	SOFT TAPE (LCD)		
-		*	J19-6072-08	HOLDER (LCD)		
-		*	J19-6074-08	HOLDER (LCD)		
P100		*	J21-5845-04	MOUNTING HARDWARE		
CF1 ,2			L72-0531-05	CERAMIC FILTER		MM1X
CF1 ,2			L72-0536-05	CERAMIC FILTER		TEHH1
CF3			L72-0607-05	CERAMIC FILTER		MM1X

L : Scandinavia K : USA P : Canada R : Mexico C : China I : Malaysia
 Y : PX(Far East,Hawaii) T : England E : Europe G : Germany V : China(Shanghai)
 Y : AAFES(Europe) X : Australia Q : Russia H : Korea M : Other Areas Δ indicates safety critical components.

PARTS LIST

RXD-M32MD

* New Parts
 Parts without **Parts No.** are not supplied.
 Les articles non mentionnés dans le **Parts No.** ne sont pas fournis.
 Teile ohne **Parts No.** werden nicht geliefert.

5

Ref. No	Add-ress	New Parts	Parts No.	Description	Desti-nation	Re-marks
L1			L39-1384-05	COMBINATION COIL		
L2			L40-1091-17	SMALL FIXED INDUCTOR(1UH)		
L3			L30-0911-05	AM IFT		
L4			L30-0950-05	FM IFT	TEHH1	
L5			L30-0951-05	FM IFT	TEHH1	
L6 ,7			L79-1236-05	LC FILTER	TEHH1	
X1			L77-2232-05	CRYSTAL RESONATOR		
R1			RK73GB1J101J	CHIP R 100	J	1/16W
R4			RK73GB1J681J	CHIP R 680	J	1/16W
R5			RK73FB2A332J	CHIP R 3.3K	J	1/10W
R6			RK73GB1J221J	CHIP R 220	J	1/16W
R7			RK73FB2A821J	CHIP R 820	J	1/10W
R8			RK73GB1J100J	CHIP R 10	J	1/16W
R8			RK73GB1J330J	CHIP R 33	J	1/16W
R9			RK73FB2A391J	CHIP R 390	J	1/10W
R10			RK73FB2A102J	CHIP R 1.0K	J	1/10W
R11			RK73GB1J220J	CHIP R 22	J	1/16W
R11			RK73GB1J330J	CHIP R 33	J	1/16W
R12			RK73FB2A101J	CHIP R 100	J	1/10W
R14			RK73FB2A101J	CHIP R 100	J	1/10W
R14			RK73FB2A271J	CHIP R 270	J	1/10W
R15			RK73GB1J333J	CHIP R 33K	J	1/16W
R16			RK73GB1J220J	CHIP R 22	J	1/16W
R17			RK73FB2A362J	CHIP R 3.6K	J	1/10W
R18			RK73GB1J302J	CHIP R 3.0K	J	1/16W
R19			RK73GB1J822J	CHIP R 8.2K	J	1/16W
R20			RK73GB1J392J	CHIP R 3.9K	J	1/16W
R23			RK73GB1J153J	CHIP R 15K	J	1/16W
R23			RK73GB1J332J	CHIP R 3.3K	J	1/16W
R25			RK73GB1J183J	CHIP R 18K	J	1/16W
R25			RK73GB1J273J	CHIP R 27K	J	1/16W
R27 ,28			RK73GB1J432J	CHIP R 4.3K	J	1/16W
R27 ,28			RK73GB1J472J	CHIP R 4.7K	J	1/16W
R30			RK73GB1J561J	CHIP R 560	J	1/16W
R31			RK73GB1J473J	CHIP R 47K	J	1/16W
R32			RK73FB2A272J	CHIP R 2.7K	J	1/10W
R33 ,34			RK73GB1J102J	CHIP R 1.0K	J	1/16W
R35			RK73GB1J101J	CHIP R 100	J	1/16W
R36			RK73GB1J102J	CHIP R 1.0K	J	1/16W
R37			RK73GB1J392J	CHIP R 3.9K	J	1/16W
R38			RK73GB1J102J	CHIP R 1.0K	J	1/16W
R39			RK73GB1J103J	CHIP R 10K	J	1/16W
R42			RK73GB1J103J	CHIP R 10K	J	1/16W
R43			RK73GB1J221J	CHIP R 220	J	1/16W
R44			RD14NB2E271J	RD 270	J	1/4W
R45 -48			RK73GB1J102J	CHIP R 1.0K	J	1/16W
R49			RK73GB1J103J	CHIP R 10K	J	1/16W
R50			RD14NB2E471J	RD 470	J	1/4W
R51			RK73GB1J562J	CHIP R 5.6K	J	1/16W
R52			RK73GB1J101J	CHIP R 100	J	1/16W
R53			RK73GB1J222J	CHIP R 2.2K	J	1/16W
R54			RK73GB1J102J	CHIP R 1.0K	J	1/16W
R55			RK73GB1J333J	CHIP R 33K	J	1/16W
R56 ,57			RK73GB1J102J	CHIP R 1.0K	J	1/16W

L : Scandinavia K : USA P : Canada R : Mexico C : China I : Malaysia
 Y : PX(Far East,Hawaii) T : England E : Europe G : Germany V : China(Shanghai)
 Y : AAFES(Europe) X : Australia Q : Russia H : Korea M : Other Areas Δ indicates safety critical components .

* New Parts
 Parts without **Parts No.** are not supplied.
 Les articles non mentionnés dans le **Parts No.** ne sont pas fournis.
 Teile ohne **Parts No.** werden nicht geliefert.

6

Ref. No	Add-ress	New Parts	Parts No.	Description	Desti-nation	Re-marks
R58			RK73FB2A123J	CHIP R 12K	J	1/10W
R59			RK73FB2A122J	CHIP R 1.2K	J	1/10W
R72 ,73			RK73GB1J392J	CHIP R 3.9K	J	1/16W
R79			RK73GB1J332J	CHIP R 3.3K	J	1/16W
R80			RK73FB2A223J	CHIP R 22K	J	1/10W
R81			RS14KB3A820J	FL-PROOF RS 82	J	1W
R82			RK73GB1J272J	CHIP R 2.7K	J	1/16W
R83			RK73FB2A102J	CHIP R 1.0K	J	1/10W
R84			RK73EB2B102J	CHIP R 1.0K	J	1/8W
R85 -87			RK73GB1J105J	CHIP R 1.0M	J	1/16W
R88			RK73GB1J563J	CHIP R 56K	J	1/16W
R89			RK73GB1J333J	CHIP R 33K	J	1/16W
R101			RK73GB1J104J	CHIP R 100K	J	1/16W
R102			RK73GB1J113J	CHIP R 11K	J	1/16W
R103			RK73GB1J243J	CHIP R 24K	J	1/16W
R104			RK73GB1J433J	CHIP R 43K	J	1/16W
R105			RK73GB1J683J	CHIP R 68K	J	1/16W
R106			RK73GB1J104J	CHIP R 100K	J	1/16W
R108			RK73GB1J682J	CHIP R 6.8K	J	1/16W
R109,110			RK73GB1J133J	CHIP R 13K	J	1/16W
R111,112			RK73GB1J221J	CHIP R 220	J	1/16W
R113			RK73GB1J332J	CHIP R 3.3K	J	1/16W
R120			RK73GB1J104J	CHIP R 100K	J	1/16W
R121			RK73GB1J113J	CHIP R 11K	J	1/16W
R122			RK73GB1J243J	CHIP R 24K	J	1/16W
R123			RK73GB1J433J	CHIP R 43K	J	1/16W
R124			RK73GB1J683J	CHIP R 68K	J	1/16W
R125			RK73GB1J104J	CHIP R 100K	J	1/16W
R126			RK73GB1J154J	CHIP R 150K	J	1/16W
R127			RK73GB1J244J	CHIP R 240K	J	1/16W
R132			RK73GB1J102J	CHIP R 1.0K	J	1/16W
R133			RK73GB1J101J	CHIP R 100	J	1/16W
R134			RK73GB1J154J	CHIP R 150K	J	1/16W
R135			RK73GB1J244J	CHIP R 240K	J	1/16W
R136			RK73GB1J394J	CHIP R 390K	J	1/16W
R137			RK73GB1J331J	CHIP R 330	J	1/16W
R138			RK73GB1J102J	CHIP R 1.0K	J	1/16W
VR1			R32-0037-05	SEMI FIXED VARIABLE RESISTOR		
W651,652			R92-0670-05	CHIP R 0 OHM		
W654-656			R92-0670-05	CHIP R 0 OHM		M1M2
W654,655			R92-0670-05	CHIP R 0 OHM		K1E1E2
W654,655			R92-0670-05	CHIP R 0 OHM		X1
W659			R92-0670-05	CHIP R 0 OHM		K1M1M2
W659			R92-0670-05	CHIP R 0 OHM		X1
W659,660			R92-0670-05	CHIP R 0 OHM		E1E2
W662			R92-0670-05	CHIP R 0 OHM		
W680			R92-0679-05	CHIP R 0 OHM		
W682-685			R92-0679-05	CHIP R 0 OHM		K1M1M2
W682-685			R92-0679-05	CHIP R 0 OHM		X1
W684,685			R92-0679-05	CHIP R 0 OHM		E1E2
S100-116			S70-0031-05	TACT SWITCH		
S117			T99-0602-05	ROTARY ENCODER		
D1			DA204U	DIODE		

L : Scandinavia K : USA P : Canada R : Mexico C : China I : Malaysia
 Y : PX(Far East,Hawaii) T : England E : Europe G : Germany V : China(Shanghai)
 Y : AAFES(Europe) X : Australia Q : Russia H : Korea M : Other Areas Δ indicates safety critical components .

* New Parts
Parts without **Parts No.** are not supplied.
Les articles non mentionnés dans le **Parts No.** ne sont pas fournis.
Teile ohne **Parts No.** werden nicht geliefert.

7

Ref. No	Add-ress	New Parts	Parts No.	Description	Desti-nation	Re-marks
D1			MA143A	DIODE		
D1			1SS302	DIODE		
D3			HZS8.2N(B2)	ZENER DIODE		
D3			MTZJ8.2(B)	ZENER DIODE		
D4			HZS5.1N(B2)	ZENER DIODE		
D4			MTZJ5.1(B)	ZENER DIODE		
D8			MA111	DIODE	TEHH1	
D11			MA111	DIODE		
D13			MA111	DIODE		
D102			UDZ5.6B	ZENER DIODE		
ED101		*	BL-150NK	FLUORESCENT INDICATOR TUBE		
IC1			LA1837	ANALOGUE IC	TEHH1	
IC1			LA1838	ANALOGUE IC	MM1X	
IC2			LC72131	MOS-IC		
Q1			2SC4081(R,S)	TRANSISTOR		
Q1			2SD1819A(Q,R)	TRANSISTOR		
Q2			2SA1576A(R,S)	TRANSISTOR		
Q2			2SB1218A(Q,R)	TRANSISTOR		
Q3 ,4			2SC4081(R,S)	TRANSISTOR	MM1	
Q3 ,4			2SD1819A(Q,R)	TRANSISTOR	MM1	
Q6 ,7			2SC4081(R,S)	TRANSISTOR	TEHH1	
Q6 ,7			2SD1819A(Q,R)	TRANSISTOR	TEHH1	
Q14			2SA1576A(R,S)	TRANSISTOR		
Q14			2SB1218A(Q,R)	TRANSISTOR		
Q100			2SD1963	TRANSISTOR		
Q101			DTA124EUA	DIGITAL TRANSISTOR		
Q101			UN5112	DIGITAL TRANSISTOR		
A1			W02-2584-05	FM FRONT-END ASSY		
A1			W02-2622-05	FM FRONT-END ASSY	TEHH1	
A100			W02-2537-05	ELECTRIC CIRCUIT MODULE	MM1X	
CONTROL CIRCUIT (X29-2690-XX)						
C1 ,2			CE04KW1H2R2M	ELECTRO	2.2UF	50WV
C3 ,4			CK73GB1H102K	CHIP C	1000PF	K
C5 ,6			CE04KW1C100M	ELECTRO	10UF	16WV
C7 ,8			CK73GB1H561K	CHIP C	560PF	K
C9 ,10			CC73GCH1H100D	CHIP C	10PF	D
C11 ,12			CK73GB1H122K	CHIP C	1200PF	K
C13 ,14			CK73GB1H561K	CHIP C	560PF	K
C15 ,16			CK73GB1H102K	CHIP C	1000PF	K
C17 -20			CQ93FMG1H224J	MYLAR	0.22UF	J
C21 ,22			CK73GB1H103K	CHIP C	0.010UF	K
C23 ,24			CC73GCH1H330J	CHIP C	33PF	J
C31			CE04HW1E100M	NP-ELEC	10UF	25WV
C33			CE04KW1E470M	ELECTRO	47UF	25WV
C41			CK73GB1H102K	CHIP C	1000PF	K
C42			CE04KW1A221M	ELECTRO	220UF	10WV
C43			CE04KW1H4R7M	ELECTRO	4.7UF	50WV
C51 ,52		*	C90-3928-05	ELECTRO	2200UF	35WV
C53 -55			C91-1567-05	FILM	0.1UF	J
C61			CE04KW1V222M	ELECTRO	2200UF	35WV
C62			CQ93FMG1H104J	MYLAR	0.10UF	J
C64			CK73GB1H102K	CHIP C	1000PF	K
C71			CE04KW1E332M	ELECTRO	3300UF	25WV
C72			CQ93FMG1H104J	MYLAR	0.10UF	J

L : Scandinavia K : USA P : Canada R : Mexico C : China I : Malaysia
Y : PX(Far East,Hawaii) T : England E : Europe G : Germany V : China(Shanghai)
Y : AAFES(Europe) X : Australia Q : Russia H : Korea M : Other Areas Δ indicates safety critical components.

* New Parts
Parts without **Parts No.** are not supplied.
Les articles non mentionnés dans le **Parts No.** ne sont pas fournis.
Teile ohne **Parts No.** werden nicht geliefert.

8

Ref. No	Add-ress	New Parts	Parts No.	Description	Desti-nation	Re-marks
C75			CQ93FMG1H473J	MYLAR	0.047UF	J
C78			CE04DW1V221M	ELECTRO	220UF	35WV
C79			CE04KW1H100M	ELECTRO	10UF	50WV
C80			CE04KW1E470M	ELECTRO	47UF	25WV
C81 ,82			CK73GB1H103K	CHIP C	0.010UF	K
C90			CK73GB1C473K	CHIP C	0.047UF	K
C91			C91-1488-05	MF	6800PF	250VAC
C92			CE04KW1E470M	ELECTRO	47UF	25WV
C93			CQ93FMG1H104J	MYLAR	0.10UF	J
C93			CQ93FMG1H184J	MYLAR	0.18UF	J
C94			CE04KW1H2R2M	ELECTRO	2.2UF	50WV
C95			CE04KW1C332M	ELECTRO	3300UF	16WV
C95			CE04KW1E332M	ELECTRO	3300UF	25WV
C98			CE04KW1E470M	ELECTRO	47UF	25WV
C101			CK73GB1H103K	CHIP C	0.010UF	K
C102			CE04KW1H010M	ELECTRO	1.0UF	50WV
C103			CE04KW0J331M	ELECTRO	330UF	6.3WV
C104			CE04KW1A101M	ELECTRO	100UF	10WV
C105			CE04KW1C471M	ELECTRO	470UF	16WV
C106			CE04KW1V101M	ELECTRO	100UF	35WV
C107,108			CE04KW1H3R3M	ELECTRO	3.3UF	50WV
C115-118			CE04KW1C100M	ELECTRO	10UF	16WV
C119,120			CK73GB1C104K	CHIP C	0.10UF	K
C121,122			CK73FB1C154K	CHIP C	0.15UF	K
C123,124			CK73FB1E683K	CHIP C	0.068UF	K
C125,126			CK73GB1A154K	CHIP C	0.15UF	K
C127,128			CK73GB1C563K	CHIP C	0.056UF	K
C129,130			CK73GB1H122K	CHIP C	1200PF	K
C131,132			CE04KW1H2R2M	ELECTRO	2.2UF	50WV
C133,134			CC73GCH1H100D	CHIP C	10PF	D
C135,136			CE04KW1H010M	ELECTRO	1.0UF	50WV
C137-140			CC73GCH1H221J	CHIP C	220PF	J
C149			CC73GCH1H100D	CHIP C	10PF	D
C150			CK73GB1C104K	CHIP C	0.10UF	K
C151			CK73GB1H102K	CHIP C	1000PF	K
C152			CK73GB1C104K	CHIP C	0.10UF	K
C153			CC73GCH1H220J	CHIP C	22PF	J
C154			CC73GCH1H180J	CHIP C	18PF	J
C155			CK73GB1H103K	CHIP C	0.010UF	K
C156			CK73GB1C104K	CHIP C	0.10UF	K
C157,158			CE04KW1C100M	ELECTRO	10UF	16WV
C159,160			CK73GB1H681K	CHIP C	680PF	K
C161-164			CC73GCH1H221J	CHIP C	220PF	J
C165,166			CE04KW1H3R3M	ELECTRO	3.3UF	50WV
C167,168			CK73GB1H103K	CHIP C	0.010UF	K
C169,170			CE04KW1A221M	ELECTRO	220UF	10WV
C171,172			CE04KW1H010M	ELECTRO	1.0UF	50WV
C173,174			CE04KW1H3R3M	ELECTRO	3.3UF	50WV
C175			CE04KW1A101M	ELECTRO	100UF	10WV
C176			CE04KW1E101M	ELECTRO	100UF	25WV
C177			CK73GB1H103K	CHIP C	0.010UF	K
C178			CC73GCH1H080D	CHIP C	8.0PF	D
C179,180			CK73GB1H472K	CHIP C	4700PF	K
C181			CK73GB1H103K	CHIP C	0.010UF	K
C182-184			CE04KW1C100M	ELECTRO	10UF	16WV

L : Scandinavia K : USA P : Canada R : Mexico C : China I : Malaysia
Y : PX(Far East,Hawaii) T : England E : Europe G : Germany V : China(Shanghai)
Y : AAFES(Europe) X : Australia Q : Russia H : Korea M : Other Areas Δ indicates safety critical components.

PARTS LIST

RXD-M32MD

* New Parts

Parts without **Parts No.** are not supplied.Les articles non mentionnés dans le **Parts No.** ne sont pas fournis.Teile ohne **Parts No.** werden nicht geliefert.

9

Ref. No	Add-ress	New Parts	Parts No.	Description	Desti-nation	Re-marks
C185			CK73FF1C105Z	CHIP C 1.0UF	Z	
C186			CQ93HP2A103J	MYLAR 0.010UF	J	
C187			CE04KW1C220M	ELECTRO 22UF	16WV	
C189,190			CE04KW1H3R3M	ELECTRO 3.3UF	50WV	
C191,192			CC73GCH1H821J	CHIP C 820PF	J	
Δ C193-196			CE04KW1H3R3M	ELECTRO 3.3UF	50WV	
C197			CE04KW1E101M	ELECTRO 100UF	25WV	
C198			CK73GB1C104K	CHIP C 0.10UF	K	
C199			CE04KW1A101M	ELECTRO 100UF	10WV	
C200			CC73GCH1H101J	CHIP C 100PF	J	
C201			CE04KW1A101M	ELECTRO 100UF	10WV	
C202			CK73GB1H103K	CHIP C 0.010UF	K	
C203			CE04KW1A471M	ELECTRO 470UF	10WV	
C204			CC73FCH1H680J	CHIP C 68PF	J	
C205			CK73GB1C104K	CHIP C 0.10UF	K	
C206			CE04KW1A101M	ELECTRO 100UF	10WV	
C212			CE04KW1A470M	ELECTRO 47UF	10WV	TEHH1
C213			CK73GB1H103K	CHIP C 0.010UF	K	TEHH1
C214			CC73GCH1H220J	CHIP C 22PF	J	TEHH1
C215			CC73GCH1H470J	CHIP C 47PF	J	TEHH1
C216			CC73GCH1H561J	CHIP C 560PF	J	TEHH1
C217			CK73GB1H103K	CHIP C 0.010UF	K	TEHH1
C218			CC73GCH1H331J	CHIP C 330PF	J	TEHH1
C219			CE04KW1H2R2M	ELECTRO 2.2UF	50WV	TEHH1
C220			CC73GCH1H101J	CHIP C 100PF	J	TEHH1
C222			CE04KW1A101M	ELECTRO 100UF	10WV	
C225,226			CC73GCH1H080D	CHIP C 8.0PF	D	
C229,230			CC73GCH1H101J	CHIP C 100PF	J	
C231			CE04KW1C471M	ELECTRO 470UF	16WV	
C232			CC73GCH1H470J	CHIP C 47PF	J	
C233			CK73GB1C104K	CHIP C 0.10UF	K	
C234			CE04KW1C331M	ELECTRO 330UF	16WV	
C235			CE04KW1E331M	ELECTRO 330UF	25WV	
C240			CK73GB1H103K	CHIP C 0.010UF	K	
C241,242			CC73GCH1H101J	CHIP C 100PF	J	
C243			CC73GCH1H220J	CHIP C 22PF	J	
C245			CK73GB1H103K	CHIP C 0.010UF	K	
C248			CK73GB1H102K	CHIP C 1000PF	K	
C249			CC73GCH1H101J	CHIP C 100PF	J	
C250			CK73GB1H103K	CHIP C 0.010UF	K	
C251			CC73GCH1H470J	CHIP C 47PF	J	
C252			CC73GCH1H220J	CHIP C 22PF	J	
C253			CC73GCH1H100D	CHIP C 10PF	D	
C254			CK73GB1H103K	CHIP C 0.010UF	K	
CN1			E40-5066-05	PIN ASSY		
CN2			E40-8605-05	PIN ASSY		
CN4			E40-3247-05	PIN ASSY		
CN91			E40-4245-05	PIN ASSY		
CN93			E40-4281-05	PIN ASSY		
CN101			E40-3251-05	PIN ASSY		
CN102			E40-4899-05	FLAT CABLE CONNECTOR		
CN103			E40-4874-05	PIN ASSY		
CN104			E40-8307-05	FLAT CABLE CONNECTOR		
CN105			E40-3248-05	PIN ASSY		

L : Scandinavia K : USA P : Canada R : Mexico C : China I : Malaysia

Y : PX(Far East,Hawaii) T : England E : Europe G : Germany V : China(Shanghai)

Y : AAFES(Europe) X : Australia Q : Russia H : Korea M : Other Areas Δ indicates safety critical components .

* New Parts

Parts without **Parts No.** are not supplied.Les articles non mentionnés dans le **Parts No.** ne sont pas fournis.Teile ohne **Parts No.** werden nicht geliefert.

10

Ref. No	Add-ress	New Parts	Parts No.	Description	Desti-nation	Re-marks
CN106			E40-3259-05	PIN ASSY		
CN108			E40-3249-05	PIN ASSY		
CN109		*	E40-8601-05	FLAT CABLE CONNECTOR		
CN111			E40-3249-05	PIN ASSY		
CN113		*	E40-8606-05	PIN ASSY		
CN114			E40-3249-05	PIN ASSY		
CN115,116		*	E40-8634-05	FLAT CABLE CONNECTOR		
CN117		*	E40-8603-05	FLAT CABLE CONNECTOR		
CN118		*	E40-8635-05	FLAT CABLE CONNECTOR		
CN119		*	E40-8613-05	FLAT CABLE CONNECTOR		
J1			E70-0053-05	LOCK TERMINAL BOARD		
J101			E63-0095-05	PIN JACK		
Δ F1			F05-8013-05	FUSE (SEMKO) (250V T800MAL)		
Δ F2			F05-8013-05	FUSE (SEMKO) (250V T800MAL)		MM1
CN95,96			J13-0075-05	FUSE CLIP		
CN97,98			J13-0075-05	FUSE CLIP		MM1
E100			J11-0809-05	WIRE CLAMPER		
L101,102			L40-1035-29	SMALL FIXED INDUCTOR(10MH, J)		
L103			L32-0592-05	BIAS OSCILLATING COIL		
L104			L40-1001-17	SMALL FIXED INDUCTOR(10UH,K)		
L105,106			L92-0089-05	CHIP FERRITE		
L107			L92-0089-05	CHIP FERRITE		
L108			L92-0017-05	FERRITE CORE		
Δ T91		*	L07-2758-05	POWER TRANSFORMER		MM1
Δ T91		*	L07-2897-08	POWER TRANSFORMER		XTEHH1
X101			L78-0294-05	RESONATOR (10.000M)		
X102			L77-2173-05	CRYSTAL RESONATOR(32.768KHZ)		
X103			L77-2002-05	CRYSTAL RESONATOR(4.332MHZ)		TEHH1
R1 ,2			RK73GB1J222J	CHIP R 2.2K	J	1/16W
R3 ,4			RK73GB1J102J	CHIP R 1.0K	J	1/16W
R5 ,6			RK73GB1J222J	CHIP R 2.2K	J	1/16W
R7 ,8			RK73GB1J203J	CHIP R 20K	J	1/16W
R9 ,10			RK73GB1J223J	CHIP R 22K	J	1/16W
R11 ,12			RK73GB1J102J	CHIP R 1.0K	J	1/16W
R13 ,14			RK73GB1J203J	CHIP R 20K	J	1/16W
R15 ,16			RK73GB1J391J	CHIP R 390	J	1/16W
R21 ,22			RS14KB3DR22J	FL-PROOF RS 0.22	J	2W
R23 ,24			RK73GB1J102J	CHIP R 1.0K	J	1/16W
R25 ,26			RK73GB1J103J	CHIP R 10K	J	1/16W
R27 ,28			RK73GB1J472J	CHIP R 4.7K	J	1/16W
R29 ,30			RK73GB1J473J	CHIP R 47K	J	1/16W
R31 ,32			RS14KB3A2R7J	FL-PROOF RS 2.7	J	1W
Δ R35			RS14KB3A101J	FL-PROOF RS 100	J	1W
R36			RK73GB1J332J	CHIP R 3.3K	J	1/16W
R37			RK73GB1J104J	CHIP R 100K	J	1/16W
R41			RK73GB1J561J	CHIP R 560	J	1/16W
R42			RK73GB1J122J	CHIP R 1.2K	J	1/16W
R43			RK73GB1J473J	CHIP R 47K	J	1/16W
R44			RK73GB1J103J	CHIP R 10K	J	1/16W
R45			RK73GB1J102J	CHIP R 1.0K	J	1/16W
R46			RK73GB1J472J	CHIP R 4.7K	J	1/16W
R47			RK73GB1J331J	CHIP R 330	J	1/16W
R48			RK73GB1J473J	CHIP R 47K	J	1/16W

L : Scandinavia K : USA P : Canada R : Mexico C : China I : Malaysia

Y : PX(Far East,Hawaii) T : England E : Europe G : Germany V : China(Shanghai)

Y : AAFES(Europe) X : Australia Q : Russia H : Korea M : Other Areas Δ indicates safety critical components .

* New Parts
 Parts without **Parts No.** are not supplied.
 Les articles non mentionnés dans le **Parts No.** ne sont pas fournis.
 Teile ohne **Parts No.** werden nicht geliefert.



Ref. No	Add-ress	New Parts	Parts No.	Description	Desti-nation	Re-marks
R50			RS14KB3A152J	FL-PROOF RS 1.5K	J	1W
R51 -53			RK73GB1J473J	CHIP R 47K	J	1/16W
R54			RK73GB1J332J	CHIP R 3.3K	J	1/16W
R55			RK73GB1J472J	CHIP R 4.7K	J	1/16W
R56			RK73GB1J103J	CHIP R 10K	J	1/16W
R57			RK73GB1J153J	CHIP R 15K	J	1/16W
R59 ,60			RS14KB3A331J	FL-PROOF RS 330	J	1W
R63			RK73GB1J102J	CHIP R 1.0K	J	1/16W
R64			RK73GB1J104J	CHIP R 100K	J	1/16W
R66			RD14NB2E1R0J	RD 1	J	1/4W
R91			RK73GB1J104J	CHIP R 100K	J	1/16W
R92			RK73GB1J332J	CHIP R 3.3K	J	1/16W
R94			RK73GB1J105J	CHIP R 1.0M	J	1/16W
R95			RK73GB1J104J	CHIP R 100K	J	1/16W
R96			RK73GB1J101J	CHIP R 100	J	1/16W
R98			RS14KB3A101J	FL-PROOF RS 100	J	1W
R98			RS14KB3A560J	FL-PROOF RS 56	J	1W
R101			RK73GB1J102J	CHIP R 1.0K	J	1/16W
R102			RK73GB1J103J	CHIP R 10K	J	1/16W
R103			RK73GB1J104J	CHIP R 100K	J	1/16W
R104			RK73GB1J102J	CHIP R 1.0K	J	1/16W
R105			RK73GB1J103J	CHIP R 10K	J	1/16W
R106			RK73GB1J2R2J	CHIP R 2.2	J	1/16W
R107,108			RK73GB1J682J	CHIP R 6.8K	J	1/16W
R109,110			RK73GB1J103J	CHIP R 10K	J	1/16W
R111,112			RK73GB1J102J	CHIP R 1.0K	J	1/16W
R113,114			RK73GB1J104J	CHIP R 100K	J	1/16W
R127			RK73GB1J102J	CHIP R 1.0K	J	1/16W
R129			RK73GB1J222J	CHIP R 2.2K	J	1/16W
R130			RK73GB1J133J	CHIP R 13K	J	1/16W
R131			RK73GB1J104J	CHIP R 100K	J	1/16W
R132			RK73FB2A475J	CHIP R 4.7M	J	1/10W
R133,134			RK73GB1J103J	CHIP R 10K	J	1/16W
R135,136			RK73GB1J164J	CHIP R 160K	J	1/16W
R137-140			RK73GB1J103J	CHIP R 10K	J	1/16W
R141,142			RK73GB1J334J	CHIP R 330K	J	1/16W
R143,144			RK73GB1J153J	CHIP R 15K	J	1/16W
R145,146			RK73GB1J223J	CHIP R 22K	J	1/16W
R147,148			RK73GB1J200J	CHIP R 20	J	1/16W
R149,150			RK73GB1J222J	CHIP R 2.2K	J	1/16W
R151,152			RK73GB1J272J	CHIP R 2.7K	J	1/16W
R153,154			RK73GB1J682J	CHIP R 6.8K	J	1/16W
R155			RK73GB1J912J	CHIP R 9.1K	J	1/16W
R156			RK73GB1J392J	CHIP R 3.9K	J	1/16W
R157			RK73GB1J223J	CHIP R 22K	J	1/16W
R159			RK73GB1J102J	CHIP R 1.0K	J	1/16W
R160			RD14GB2E100J	FL-PROOF RD 10	J	1/4W
R163,164			RK73GB1J273J	CHIP R 27K	J	1/16W
R165			RD14GB2E100J	FL-PROOF RD 10	J	1/4W
R166			RK73GB1J103J	CHIP R 10K	J	1/16W
R167			RK73GB1J182J	CHIP R 1.8K	J	1/16W
R168			RK73GB1J102J	CHIP R 1.0K	J	1/16W
R169			RK73GB1J103J	CHIP R 10K	J	1/16W
R170			RD14GB2E100J	FL-PROOF RD 10	J	1/4W
R171-175			RK73GB1J101J	CHIP R 100	J	1/16W

L : Scandinavia K : USA P : Canada R : Mexico C : China I : Malaysia
 Y : PX(Far East,Hawaii) T : England E : Europe G : Germany V : China(Shanghai)
 Y : AAFES(Europe) X : Australia Q : Russia H : Korea M : Other Areas Δ indicates safety critical components.

* New Parts
 Parts without **Parts No.** are not supplied.
 Les articles non mentionnés dans le **Parts No.** ne sont pas fournis.
 Teile ohne **Parts No.** werden nicht geliefert.



Ref. No	Add-ress	New Parts	Parts No.	Description	Desti-nation	Re-marks
R176-180			RK73GB1J472J	CHIP R 4.7K	J	1/16W
R181			RK73GB1J562J	CHIP R 5.6K	J	1/16W
R182			RK73GB1J473J	CHIP R 47K	J	1/16W
R183			RK73GB1J272J	CHIP R 2.7K	J	1/16W
R184			RK73GB1J473J	CHIP R 47K	J	1/16W
R185			RK73GB1J472J	CHIP R 4.7K	J	1/16W
R186			RK73GB1J102J	CHIP R 1.0K	J	1/16W
R187,188			RK73GB1J332J	CHIP R 3.3K	J	1/16W
R189,190			RK73GB1J912J	CHIP R 9.1K	J	1/16W
R191,192			RK73GB1J223J	CHIP R 22K	J	1/16W
R193,194			RK73GB1J103J	CHIP R 10K	J	1/16W
R195,196			RK73GB1J104J	CHIP R 100K	J	1/16W
R197			RK73GB1J100J	CHIP R 10	J	1/16W
R198			RK73GB1J471J	CHIP R 470	J	1/16W
R199			RK73GB1J473J	CHIP R 47K	J	1/16W
R200			RK73GB1J102J	CHIP R 1.0K	J	1/16W
R201,202			RK73GB1J101J	CHIP R 100	J	1/16W
R203,204			RK73GB1J104J	CHIP R 100K	J	1/16W
R205			RK73GB1J100J	CHIP R 10	J	1/16W
R208			RK73GB1J363J	CHIP R 36K	J	1/16W
R209			RK73GB1J473J	CHIP R 47K	J	1/16W
R213			RK73GB1J222J	CHIP R 2.2K	J	1/16W
R214			RK73GB1J101J	CHIP R 100	J	1/16W
R215			RK73GB1J473J	CHIP R 47K	J	1/16W
R216			RK73GB1J101J	CHIP R 100	J	1/16W
R218,219			RK73GB1J472J	CHIP R 4.7K	J	1/16W
R220			RK73GB1J473J	CHIP R 47K	J	1/16W
R221			RK73GB1J102J	CHIP R 1.0K	J	1/16W
R222,223			RK73GB1J472J	CHIP R 4.7K	J	1/16W
R224			RK73GB1J102J	CHIP R 1.0K	J	1/16W
R225,226			RK73GB1J473J	CHIP R 47K	J	1/16W
R227			RD14BB2E2R2J	RD 2.2	J	1/4W
R228			RK73GB1J121J	CHIP R 120	J	1/16W
R229-231			RK73GB1J101J	CHIP R 100	J	1/16W
R232,233			RK73GB1J100J	CHIP R 10	J	1/16W
R234,235			RK73GB1J101J	CHIP R 100	J	1/16W
R236			RK73GB1J103J	CHIP R 10K	J	1/16W
R237			RK73GB1J101J	CHIP R 100	J	1/16W
R238			RK73GB1J561J	CHIP R 560	J	1/16W
R239,240			RK73GB1J101J	CHIP R 100	J	1/16W
R241,242			RK73GB1J162J	CHIP R 1.6K	J	1/16W
R243,244			RK73GB1J332J	CHIP R 3.3K	J	1/16W
R245			RK73GB1J101J	CHIP R 100	J	1/16W
R247-258			RK73GB1J101J	CHIP R 100	J	1/16W
R259			RK73GB1J332J	CHIP R 3.3K	J	1/16W
R260			RK73GB1J101J	CHIP R 100	J	1/16W
R261			RK73GB1J103J	CHIP R 10K	J	1/16W
R262			RK73GB1J102J	CHIP R 1.0K	J	1/16W
R263			RK73GB1J2R2J	CHIP R 2.2	J	1/16W
R264			RK73GB1J101J	CHIP R 100	J	1/16W
R265			RK73GB1J472J	CHIP R 4.7K	J	1/16W
R266			RS14KB3A1R0J	FL-PROOF RS 1	J	1W
R267			RK73GB1J473J	CHIP R 47K	J	1/16W
R268-279			RK73GB1J101J	CHIP R 100	J	1/16W
R280-282			RK73GB1J473J	CHIP R 47K	J	1/16W

L : Scandinavia K : USA P : Canada R : Mexico C : China I : Malaysia
 Y : PX(Far East,Hawaii) T : England E : Europe G : Germany V : China(Shanghai)
 Y : AAFES(Europe) X : Australia Q : Russia H : Korea M : Other Areas Δ indicates safety critical components.

PARTS LIST

RXD-M32MD

* New Parts
Parts without **Parts No.** are not supplied.
Les articles non mentionnés dans le **Parts No.** ne sont pas fournis.
Teile ohne **Parts No.** werden nicht geliefert.

13

Ref. No	Add-ress	New Parts	Parts No.	Description	Desti-nation	Re-marks
R283,284			RK73GB1J332J	CHIP R 3.3K J 1/16W		
R285			RK73GB1J162J	CHIP R 1.6K J 1/16W		
R286,287			RK73GB1J101J	CHIP R 100 J 1/16W		
R288			RK73GB1J162J	CHIP R 1.6K J 1/16W		
R289			RK73GB1J101J	CHIP R 100 J 1/16W		
R290			RK73GB1J271J	CHIP R 270 J 1/16W		
R291			RK73GB1J104J	CHIP R 100K J 1/16W		
R292			RK73GB1J104J	CHIP R 100K J 1/16W	MM1	
R292			RK73GB1J123J	CHIP R 12K J 1/16W	XTEHH1	
R292			RK73GB1J473J	CHIP R 47K J 1/16W	X	
R293			RK73GB1J511J	CHIP R 510 J 1/16W		
R294-296			RK73GB1J103J	CHIP R 10K J 1/16W		
R297,298			RK73GB1J153J	CHIP R 15K J 1/16W		
R299			RK73GB1J101J	CHIP R 100 J 1/16W		
R300			RD14GB2E5R6J	FL-PROOF RD 5.6 J 1/4W		
R301,302			RK73GB1J123J	CHIP R 12K J 1/16W		
R303			RK73GB1J102J	CHIP R 1.0K J 1/16W		
R305,306			RK73GB1J133J	CHIP R 13K J 1/16W		
R307,308			RK73GB1J182J	CHIP R 1.8K J 1/16W		
VR101,102			R32-0041-05	SEMI FIXED VARIABLE RESISTOR		
W502-504			R92-0670-05	CHIP R 0 OHM	E1E2	
W508			R92-0670-05	CHIP R 0 OHM	K1M1M2	
W508-510			R92-0670-05	CHIP R 0 OHM	X1X2	
W508-510			R92-0670-05	CHIP R 0 OHM	E1E2	
W510			R92-0670-05	CHIP R 0 OHM		
W512-517			R92-0679-05	CHIP R 0 OHM	K1M1M2	
W518,519			R92-0670-05	CHIP R 0 OHM	X1X2	
W518,519			R92-0670-05	CHIP R 0 OHM	E1E2	
W519			R92-0670-05	CHIP R 0 OHM	M1X1E1	
W520			R92-0679-05	CHIP R 0 OHM		
W522,523			R92-0679-05	CHIP R 0 OHM		
K1			S76-0076-05	MAGNETIC RELAY		
K91			S76-0099-05	MAGNETIC RELAY		
S91			S62-0001-05	SLIDE SWITCH	MM1	
D1			D3SBA20F03	DIODE		
D2			D2SBA20F03	DIODE		
D3			D4SBL20UF03	DIODE		
D4			MTZJ3.9(B)	ZENER DIODE		
D4			RD3.9ES(B2)	ZENER DIODE		
D5			MTZJ5.1(B)	ZENER DIODE		
D5			RD5.1ES(B2)	ZENER DIODE		
D6 ,7			MA111	DIODE		
D8			HSS104A	DIODE		
D8			1SS133	DIODE		
D9 ,10			MA111	DIODE		
D13 -16			MA111	DIODE		
D21			MTZJ10(B)	ZENER DIODE		
D21			RD10ES(B2)	ZENER DIODE		
D22			MTZJ6.8(B)	ZENER DIODE		
D22			RD6.8ES(B2)	ZENER DIODE		
D23			MTZJ10(B)	ZENER DIODE		
D23			RD10ES(B2)	ZENER DIODE		
D24			MTZJ8.2(B)	ZENER DIODE		
D24			RD8.2ES(B2)	ZENER DIODE		

L : Scandinavia K : USA P : Canada R : Mexico C : China I : Malaysia
Y : PX(Far East,Hawaii) T : England E : Europe G : Germany V : China(Shanghai)
Y : AAFES(Europe) X : Australia Q : Russia H : Korea M : Other Areas Δ indicates safety critical components.

14

* New Parts
Parts without **Parts No.** are not supplied.
Les articles non mentionnés dans le **Parts No.** ne sont pas fournis.
Teile ohne **Parts No.** werden nicht geliefert.

Ref. No	Add-ress	New Parts	Parts No.	Description	Desti-nation	Re-marks
D43		*	MTZJ9.1(B)	ZENER DIODE		
D43			RD9.1ES(B2)	ZENER DIODE		
D44		*	DSK10B-AT	DIODE		
D90			MA111	DIODE	MM1	
D91			S1ZB20(4072)	DIODE		
D92 -94			MA111	DIODE	XTEHH1	
D95 ,96			MA111	DIODE		
D97 ,98			MA111	DIODE	MM1	
D99			MA111	DIODE		
D101			1SS402	DIODE		
D102			HSS104A	DIODE		
D102			1SS133	DIODE		
D103			MTZJ5.6(B)	ZENER DIODE		
D103			RD5.6ES(B2)	ZENER DIODE		
D105			MTZJ5.6(B)	ZENER DIODE		
D105			RD5.6ES(B2)	ZENER DIODE		
D106,107			HSS104A	DIODE		
D106,107			1SS133	DIODE		
D108			MTZJ5.1(B)	ZENER DIODE		
D108			RD5.1ES(B2)	ZENER DIODE		
D109			MTZJ6.8(B)	ZENER DIODE		
D109			RD6.8ES(B2)	ZENER DIODE		
D110			MA111	DIODE		
D111			HSS104A	DIODE		
D111			1SS133	DIODE		
D114			HSS104A	DIODE		
D114			1SS133	DIODE		
D115			MA111	DIODE		
D116			MTZJ5.6(B)	ZENER DIODE		
D116			RD5.6ES(B2)	ZENER DIODE		
IC1		*	LM4766T	ANALOGUE IC		
IC2			TA7812S	ANALOGUE IC		
IC91			XC62HR5102P	ANALOGUE IC		
IC92		*	NJM2930F05	ANALOGUE IC	MM1	
IC101			S-80840ANY	ANALOGUE IC		
IC103			TA8409S	MOS-IC		
IC104			M30624MG-307FP	MI-COM IC		
IC105		*	M62498AFP	ANALOGUE IC		
IC106			HA12219NT	ANALOGUE IC		
IC107			BA3126N	ANALOGUE IC		
IC108			TC74HCT7007AF	MOS-IC		
IC109			NJM4565D	ANALOGUE IC		
IC110			BA05T	ANALOGUE IC		
IC110			BA17805T	ANALOGUE IC		
IC110			LM2940CT-5.0	ANALOGUE IC		
IC110			TA7805S	ANALOGUE IC		
IC110			UPC7805AHF	ANALOGUE IC		
IC111			TA8409S	MOS-IC		
IC112			L88M33T	ANALOGUE IC		
IC114			SAA6579T/R	ANALOGUE IC	TEHH1	
Q1 ,2			2SC2878(B)	TRANSISTOR		
Q3 -5		*	2SC2362(G,H)	TRANSISTOR		
Q7			2SA933AS(Q,R)	TRANSISTOR		
Q8		*	2SA1016(G,H)	TRANSISTOR		
Q9			2SC4081(R,S)	TRANSISTOR		

L : Scandinavia K : USA P : Canada R : Mexico C : China I : Malaysia
Y : PX(Far East,Hawaii) T : England E : Europe G : Germany V : China(Shanghai)
Y : AAFES(Europe) X : Australia Q : Russia H : Korea M : Other Areas Δ indicates safety critical components.

* New Parts

Parts without **Parts No.** are not supplied.

Les articles non mentionnés dans le **Parts No.** ne sont pas fournis.

Teile ohne **Parts No.** werden nicht geliefert.

15

Ref. No	Add-ress	New Parts	Parts No.	Description	Desti-nation	Re-marks
Q9			2SC4116(Y,GR)	TRANSISTOR		
Q10			2SD2012	TRANSISTOR		
Q10			2SD2061	TRANSISTOR		
Q11 ,12		*	2SC2362(G,H)	TRANSISTOR		
Q13		*	2SA1016(G,H)	TRANSISTOR		
Q21			2SB1640	TRANSISTOR		
Q91		*	2SC2362(G,H)	TRANSISTOR		
Q92		*	2SA1016(G,H)	TRANSISTOR		
Q101			2SC2458(Y,GR)	TRANSISTOR		
Q101			2SC2785(F,E)	TRANSISTOR		
Q102			2SC2003(L,K)	TRANSISTOR		
Q103			2SB764(E,F)	TRANSISTOR		
Q104			2SA1286-T11	TRANSISTOR		
Q105,106			DTC124ESA	DIGITAL TRANSISTOR		
Q105,106			UN4212	DIGITAL TRANSISTOR		
Q107			2SC2458(Y,GR)	TRANSISTOR		
Q107			2SC2785(F,E)	TRANSISTOR		
Q108			2SC4081(R,S)	TRANSISTOR		
Q108			2SC4116(Y,GR)	TRANSISTOR		
Q109			2SD863(E,F)	TRANSISTOR		
Q110			DTA124ESA	DIGITAL TRANSISTOR		
Q110			UN4112	DIGITAL TRANSISTOR		
Q111,112			DTC124ESA	DIGITAL TRANSISTOR		
Q111,112			UN4212	DIGITAL TRANSISTOR		
Q113			DTA124ESA	DIGITAL TRANSISTOR		
Q113			UN4112	DIGITAL TRANSISTOR		
Q114			DTC124ESA	DIGITAL TRANSISTOR		
Q114			UN4212	DIGITAL TRANSISTOR		
Q117			2SC2003(L,K)	TRANSISTOR		
Q118			2SA1286-T11	TRANSISTOR		
Q119			DTC124ESA	DIGITAL TRANSISTOR		
Q119			UN4212	DIGITAL TRANSISTOR		
Q120			2SC3246	TRANSISTOR		
CD PLAYER UNIT (X32-3810-00)						
C1 ,2			C92-0084-05	CHIP C	100UF	4WV
C3			CK73GCH1H150J	CHIP C	15PF	J
C4			CC73GCH1H100D	CHIP C	10PF	D
C5			C92-0084-05	CHIP C	100UF	4WV
C6			C92-0044-05	CHIP-ELE	47UF	10WV
C7			CK73FB1C104K	CHIP C	0.10UF	K
C8			CK73FB1H563K	CHIP C	0.056UF	K
C9			C92-0085-05	CHIP C	220UF	4WV
C10			CC73GCH1H471J	CHIP C	470PF	J
C11			CK73FB1H223K	CHIP C	0.022UF	K
C12			CK73GB1H221K	CHIP C	220PF	K
C13			CK73FB1C474K	CHIP C	0.47UF	K
C14			CK73GB1H332K	CHIP C	3300PF	K
C15			CK73GB1H103K	CHIP C	0.010UF	K
C16			CK73GB1C473K	CHIP C	0.047UF	K
C17			CK73GB1H152K	CHIP C	1500PF	K
C18 ,19			CC73GCH1H150J	CHIP C	15PF	J
C20			CK73GB1H103K	CHIP C	0.010UF	K
C21 ,22			CC73FCH1H681J	CHIP C	680PF	J
C23 ,24			CC73GCH1H101J	CHIP C	100PF	J

L : Scandinavia K : USA P : Canada R : Mexico C : China I : Malaysia
 Y : PX(Far East,Hawaii) T : England E : Europe G : Germany V : China(Shanghai)
 Y : AAFES(Europe) X : Australia Q : Russia H : Korea M : Other Areas Δ indicates safety critical components.

* New Parts

Parts without **Parts No.** are not supplied.

Les articles non mentionnés dans le **Parts No.** ne sont pas fournis.

Teile ohne **Parts No.** werden nicht geliefert.

15

Ref. No	Add-ress	New Parts	Parts No.	Description	Desti-nation	Re-marks
C29			CK73GB1H221K	CHIP C	220PF	K
C30			CK73GB1H103K	CHIP C	0.010UF	K
C31			C92-0095-05	CHIP C	330UF	6.3WV
C32			CC73FSL1H101J	CHIP C	100PF	J
C33			CK73GB1H102K	CHIP C	1000PF	K
C34			CK73GB1C104K	CHIP C	0.10UF	K
C35			C92-0084-05	CHIP C	100UF	4WV
C36			CK73GB1H103K	CHIP C	0.010UF	K
C38			CK73GB1H102K	CHIP C	1000PF	K
CN1			E40-9963-05	FLAT CABLE CONNECTOR		
CN2		*	E40-8600-05	FLAT CABLE CONNECTOR		
CN3			E40-3248-05	PIN ASSY		
L1 ,2			L40-1001-31	SMALL FIXED INDUCTOR (10UH,K)		
L3		*	L33-0591-05	SMALL FIXED INDUCTOR		
L4			L40-1001-31	SMALL FIXED INDUCTOR (10UH,K)		
L5			L92-0308-05	FERRITTE CORE		
X1		*	L77-2295-05	CRYSTAL RESONATOR (33.8688MHZ)		
R1			RK73GB1J224J	CHIP R	220K	J 1/16W
R6			RK73GB1J224J	CHIP R	220K	J 1/16W
R7			RK73GB1J100J	CHIP R	10	J 1/16W
R8 ,9			RK73GB1J273J	CHIP R	27K	J 1/16W
R10			RK73GB1J622J	CHIP R	6.2K	J 1/16W
R11 ,12			RK73GB1J101J	CHIP R	100	J 1/16W
R13 ,14			RK73GB1J103J	CHIP R	10K	J 1/16W
R15			RK73GB1J153J	CHIP R	15K	J 1/16W
R16			RK73GB1J273J	CHIP R	27K	J 1/16W
R17			RK73GB1J474J	CHIP R	470K	J 1/16W
R18			RK73GB1J364J	CHIP R	360K	J 1/16W
R19			RK73GB1J102J	CHIP R	1.0K	J 1/16W
R20			RK73GB1J472J	CHIP R	4.7K	J 1/16W
R21			RK73GB1J182J	CHIP R	1.8K	J 1/16W
R22			RK73GB1J224J	CHIP R	220K	J 1/16W
R23			RK73GB1J154J	CHIP R	150K	J 1/16W
R24			RK73GB1J133J	CHIP R	13K	J 1/16W
R25			RK73GB1J225J	CHIP R	2.2M	J 1/16W
R26 ,27			RK73GB1J153J	CHIP R	15K	J 1/16W
R28			RK73GB1J104J	CHIP R	100K	J 1/16W
R29			RK73GB1J333J	CHIP R	33K	J 1/16W
R30			RK73GB1J104J	CHIP R	100K	J 1/16W
R31			RK73GB1J105J	CHIP R	1.0M	J 1/16W
R32			RK73GB1J103J	CHIP R	10K	J 1/16W
R33 ,34			RK73GB1J332J	CHIP R	3.3K	J 1/16W
R35			RK73GB1J472J	CHIP R	4.7K	J 1/16W
R36			RK73GB1J511J	CHIP R	510	J 1/16W
R37 ,38			RK73GB1J221J	CHIP R	220	J 1/16W
R40			RK73GB1J471J	CHIP R	470	J 1/16W
R41 ,42			RK73GB1J105J	CHIP R	1.0M	J 1/16W
R43 -48			RK73GB1J273J	CHIP R	27K	J 1/16W
R49			RK73GB1J100J	CHIP R	10	J 1/16W
R50			RK73GB1J473J	CHIP R	47K	J 1/16W
R51			RK73GB1J101J	CHIP R	100	J 1/16W
R52			RK73GB1J221J	CHIP R	220	J 1/16W
R53			RK73GB1J101J	CHIP R	100	J 1/16W
R54 -59			RK73GB1J221J	CHIP R	220	J 1/16W

L : Scandinavia K : USA P : Canada R : Mexico C : China I : Malaysia
 Y : PX(Far East,Hawaii) T : England E : Europe G : Germany V : China(Shanghai)
 Y : AAFES(Europe) X : Australia Q : Russia H : Korea M : Other Areas Δ indicates safety critical components.

PARTS LIST

RXD-M32MD

* New Parts
Parts without **Parts No.** are not supplied.
Les articles non mentionnés dans le **Parts No.** ne sont pas fournis.
Teile ohne **Parts No.** werden nicht geliefert.

17

Ref. No	Add-ress	New Parts	Parts No.	Description	Desti-nation	Re-marks
R60			RK73GB1J101J	CHIP R 100 J 1/16W		
R61 ,62			RK73GB1J2R2J	CHIP R 2.2 J 1/16W		
R63			RK73GB1J473J	CHIP R 47K J 1/16W		
R65 ,66			RK73GB1J104J	CHIP R 100K J 1/16W		
R67 ,68			RK73GB1J101J	CHIP R 100 J 1/16W		
VR1			R32-0018-05	SEMI FIXED VARIABLE RESISTOR		
W1			R92-0679-05	CHIP R 0 OHM		
D1 ,2			MA111	DIODE		
IC1			CXA1821M	ANALOGUE IC		
IC2		*	BA5974FP	ANALOGUE IC		
IC3		*	CXD3017Q	MOS-IC		
IC4		*	HD74UH08	MOS-IC		
Q1			2SA1576A(R,S)	TRANSISTOR		
Q2			DTA124EUA	DIGITAL TRANSISTOR		
Q3			UN5112	DIGITAL TRANSISTOR		
Q4 -6		*	2SC4213(B)	TRANSISTOR		
Q4 -6		*	2SK1580	FET		
Q4 -6			2SK1958	FET		
MD UNIT						
C1100			C92-0171-08	CHIP-C 4.7UF K		
C1101			C93-0033-08	CERAMIC 1UF Z		
C1102			CK73FF1C105Z	CHIP C 1.0UF Z		
C1103			CK73FB1H273K	CHIP C 0.027UF K		
C1104			CK73FB1H333K	CHIP C 0.033UF K		
C1105			CK73GB1H332K	CHIP C 3300PF K		
C1106			C93-0033-08	CERAMIC 1UF K		
C1107			CK73GB1C333K	CHIP C 0.033UF K		
C1108			CK73FB1C474K	CHIP C 0.47UF K		
C1109			C93-0033-08	CERAMIC 1UF K		
C1110			CK73FB1H472K	CHIP C 4700PF K		
C1111			CK73FB1C474K	CHIP C 0.47UF K		
C1112			C93-0044-08	CERAMIC 330PF J		
C1113-117			C93-0034-08	CERAMIC 270PF J		
C1118			CK73FF1C105Z	CHIP C 1.0UF Z		
C1119			C93-0033-08	CERAMIC 1UF K		
C1200			CK73FF1C105Z	CHIP C 1.0UF Z		
C1201			C92-0172-08	CHIP-C 10UF K		
C1202,203			CK73FF1C105Z	CHIP C 1.0UF Z		
C1204			CK73GB1C473K	CHIP C 0.047UF K		
C1205			CK73FF1C105Z	CHIP C 1.0UF Z		
C1206			CK73GB1H122K	CHIP C 1200PF K		
C1207			CK73FF1C105Z	CHIP C 1.0UF Z		
C1208,209			CC73GCH1H120J	CHIP C 12PF J		
C1210			CC73GCH1H220J	CHIP C 22PF J		
C1300			CC73FCH1H470J	CHIP C 47PF J		
C1301			CK73GB1C273K	CHIP C 0.027UF K		
C1302			C92-0172-08	CHIP-C 10UF K		
C1303			CK73FF1C105Z	CHIP C 1.0UF Z		
C1304			CC73FCH1H221J	CHIP C 220PF J		
C1402			CK73GB1C223K	CHIP C 0.022UF K		
C1403			CK73GF1E104Z	CHIP C 0.10UF Z		
C1404			CK73GB1C473K	CHIP C 0.047UF K		
C1405,406			CK73GB1H681K	CHIP C 680PF K		
C1407			CK73GB1C473K	CHIP C 0.047UF K		

L : Scandinavia K : USA P : Canada R : Mexico C : China I : Malaysia
Y : PX(Far East,Hawaii) T : England E : Europe G : Germany V : China(Shanghai)
Y : AAFES(Europe) X : Australia Q : Russia H : Korea M : Other Areas Δ indicates safety critical components .

18

* New Parts
Parts without **Parts No.** are not supplied.
Les articles non mentionnés dans le **Parts No.** ne sont pas fournis.
Teile ohne **Parts No.** werden nicht geliefert.

Ref. No	Add-ress	New Parts	Parts No.	Description	Desti-nation	Re-marks
C1409			CK73FF1C105Z	CHIP C 1.0UF Z		
C1411			CK73GB1C223K	CHIP C 0.022UF K		
C1501			CK73FF1C105Z	CHIP C 1.0UF Z		
C1502			C93-0044-08	CERAMIC 330PF J		
C1503			CK73EB1C334K	CHIP C 0.33UF K		
C1505			CK73GB1C473K	CHIP C 0.047UF K		
C1506			CC73GCH1H101J	CHIP C 100PF J		
C1507			CK73GB1C473K	CHIP C 0.047UF K		
C1509			CC73GCH1H101J	CHIP C 100PF J		
C1601-604			CC73GSL1H821J	CHIP C 820PF J		
C1606			C92-0172-08	CHIP-C 10UF K		
C1607			CK73FF1C105Z	CHIP C 1.0UF Z		
C1610			C92-0171-08	CHIP-C 4.7UF K		
C1611,612			CK73GB1H562K	CHIP C 5600PF K		
C1613			CK73GB1E153K	CHIP C 0.015UF K		
C1615			CK73GB1E153K	CHIP C 0.015UF K		
C1616			C92-0151-08	ELECTRO 100UF 10WV		
C1619			C93-0044-08	CERAMIC 330PF J		
C1655			CK73GB1E153K	CHIP C 0.015UF K		
C1700,701			C92-0162-08	ELECTRO 47UF 4WV		
C1702			CK73GB1H102K	CHIP C 1000PF K		
C1703			CK73GF1E104Z	CHIP C 0.10UF Z		
C1704			C92-0162-08	ELECTRO 47UF 4WV		
C1705			CK73GF1E104Z	CHIP C 0.10UF Z		
C1706			CK73FF1H103Z	CHIP C 0.010UF Z		
C1707			CK73FF1C105Z	CHIP C 1.0UF Z		
C1708,709			CK73FF1H103Z	CHIP C 0.010UF Z		
C1710			C92-0173-08	ELECTRO 10UF 16WV		
C1711			C92-0162-08	ELECTRO 47UF 4WV		
C1712			C92-0173-08	ELECTRO 10UF 16WV		
C1713			CK73FF1H103Z	CHIP C 0.010UF Z		
C1714			CK73FF1C105Z	CHIP C 1.0UF Z		
C1715			CK73FB1C104K	CHIP C 0.10UF K		
C1716			C92-0162-08	ELECTRO 47UF 4WV		
C1741			CC73GSL1H821J	CHIP C 820PF J		
C1750			CC73GSL1H821J	CHIP C 820PF J		
C1800			C92-0174-08	ELECTRO 220UF 4WV		
C1801,802			C92-0172-08	CHIP-C 10UF K		
C1803			C92-0151-08	ELECTRO 100UF 10WV		
C1804			CK73EF1C225Z	CHIP C 2.2UF Z		
C1805			CK73FF1C105Z	CHIP C 1.0UF Z		
CN1101		*	E40-8618-08	FLAT CABLE CONNECTOR,28P		
CN1300		*	E40-8619-08	PIN ASSY 2P		
CN1401		*	E40-8211-08	FLAT CABLE CONNECTOR,5P		
CN1402		*	E40-8620-08	FLAT CABLE CONNECTOR,6P		
CN1501		*	E40-8371-08	FLAT CABLE CONNECTOR,28P		
CN1502		*	E40-8641-08	PIN ASSY		
CN1931		*	E40-8211-08	FLAT CABLE CONNECTOR		
CN1932		*	E40-8617-08	FLAT CABLE CONNECTOR		
PCB-E	3C	*	J70-1449-08	PC BOARD		
L1100			L90-0100-08	COIL		
L1101			L90-0099-08	COIL		
L1200			L90-0301-08	COIL		

L : Scandinavia K : USA P : Canada R : Mexico C : China I : Malaysia
Y : PX(Far East,Hawaii) T : England E : Europe G : Germany V : China(Shanghai)
Y : AAFES(Europe) X : Australia Q : Russia H : Korea M : Other Areas Δ indicates safety critical components .

* New Parts

Parts without **Parts No.** are not supplied.
Les articles non mentionnés dans le **Parts No.** ne sont pas fournis.
Teile ohne **Parts No.** werden nicht geliefert.

19

Ref. No	Add-ress	New Parts	Parts No.	Description	Desti-nation	Re-marks
L1201			L90-0100-08	COIL		
L1300			L90-0322-08	COIL		
L1501			L90-0303-08	COIL		
L1502			L90-0301-08	COIL		
L1551,552			L90-0100-08	COIL		
L1553			R92-1824-08	COIL		
L1554			L90-0100-08	COIL		
L1600			L90-0303-08	COIL		
L1701,702			L90-0099-08	COIL		
LX1201			L77-2224-08	CRYSTAL RESONATOR		
R1100			RK73EB2B270J	CHIP R	27	J 1/8W
R1101			RK73GB1J1R0J	CHIP R	1	J 1/16W
R1102			RK73GB1J103J	CHIP R	10K	J 1/16W
R1103			RK73GB1J394J	CHIP R	390K	J 1/16W
R1105			RK73GB1J122J	CHIP R	1.2K	J 1/16W
R1106			RK73GB1J563J	CHIP R	56K	J 1/16W
R1107			RK73GB1J561J	CHIP R	560	J 1/16W
R1108-112			RK73GB1J223J	CHIP R	22K	J 1/16W
R1200,201		*	R92-1947-08	CHIP R	100K	F 1/16W
R1202,203		*	R92-1948-08	CHIP R	120K	F 1/16W
R1204,205			RK73GB1J823J	CHIP R	82K	J 1/16W
R1206,207			RK73GB1J623J	CHIP R	62K	J 1/16W
R1208			RK73GB1J221J	CHIP R	220	J 1/16W
R1209			RK73GB1J101J	CHIP R	100	J 1/16W
R1210,211			RK73GB1J221J	CHIP R	220	J 1/16W
R1212			RK73GB1J470J	CHIP R	47	J 1/16W
R1214			RK73GB1J103J	CHIP R	10K	J 1/16W
R1215			RK73GB1J105J	CHIP R	1.0M	J 1/16W
R1217			RK73GB1J151J	CHIP R	150	J 1/16W
R1230			R92-1823-08	JUMPER R	0	J 1/16W
R1300			RK73FB2A8R2J	CHIP R	8.2	J 1/10W
R1301			RK73GB1J100J	CHIP R	10	J 1/16W
R1304			RK73FB2A151J	CHIP R	150	J 1/10W
R1401			RK73GB1J272J	CHIP R	2.7K	J 1/16W
R1403			RK73GB1J471J	CHIP R	470	J 1/16W
R1405			RK73GB1J104J	CHIP R	100K	J 1/16W
R1406			RK73GB1J103J	CHIP R	10K	J 1/16W
R1407,408			RK73GB1J332J	CHIP R	3.3K	J 1/16W
R1409			R92-1823-08	JUMPER R	0	J 1/16W
R1414			RK73GB1J224J	CHIP R	220K	J 1/16W
R1415			RK73GB1J102J	CHIP R	1.0K	J 1/16W
R1417,418			RK73GB1J102J	CHIP R	1.0K	J 1/16W
R1420			RK73GB1J102J	CHIP R	1.0K	J 1/16W
R1424			RK73GB1J473J	CHIP R	47K	J 1/16W
R1430			RK73GB1J103J	CHIP R	10K	J 1/16W
R1435			RK73GB1J103J	CHIP R	10K	J 1/16W
R1440			RK73GB1J101J	CHIP R	100	J 1/16W
R1441			RK73GB1J473J	CHIP R	47K	J 1/16W
R1443			RK73GB1J102J	CHIP R	1.0K	J 1/16W
R1444			RK73GB1J103J	CHIP R	10K	J 1/16W
R1460,461			RK73GB1J103J	CHIP R	10K	J 1/16W
R1462			R92-1823-08	JUMPER R	0	J 1/16W
R1463			RK73GB1J103J	CHIP R	10K	J 1/16W
R1510			RK73GB1J102J	CHIP R	1.0K	J 1/16W
R1511			RK73GB1J822J	CHIP R	8.2K	J 1/16W

L : Scandinavia K : USA P : Canada R : Mexico C : China I : Malaysia
Y : PX(Far East,Hawaii) T : England E : Europe G : Germany V : China(Shanghai)
Y : AAFES(Europe) X : Australia Q : Russia H : Korea M : Other Areas Δ indicates safety critical components.

* New Parts

Parts without **Parts No.** are not supplied.
Les articles non mentionnés dans le **Parts No.** ne sont pas fournis.
Teile ohne **Parts No.** werden nicht geliefert.

20

Ref. No	Add-ress	New Parts	Parts No.	Description	Desti-nation	Re-marks
R1512			RK73FB2A470J	CHIP R	47	J 1/10W
R1513			RK73GB1J822J	CHIP R	8.2K	J 1/16W
R1515,516			RK73GB1J182J	CHIP R	1.8K	J 1/16W
R1517,518			RK73GB1J470J	CHIP R	47	J 1/16W
R1520			RK73GB1J473J	CHIP R	47K	J 1/16W
R1521			RK73GB1J121J	CHIP R	120	J 1/16W
R1523			RK73GB1J473J	CHIP R	47K	J 1/16W
R1524,525			R92-1824-08	JUMPER R	0	J 1/10W
R1526			RK73GB1J682J	CHIP R	6.8K	J 1/16W
R1527			RK73GB1J473J	CHIP R	47K	J 1/16W
R1528			R92-1824-08	JUMPER R	0	J 1/10W
R1529			RK73GB1J221J	CHIP R	220	J 1/16W
R1530			R92-1823-08	JUMPER R	0	J 1/16W
R1532			RK73GB1J332J	CHIP R	3.3K	J 1/16W
R1533-536			RK73GB1J102J	CHIP R	1.0K	J 1/16W
R1537,538			RK73GB1J221J	CHIP R	220	J 1/16W
R1539			RK73GB1J121J	CHIP R	120	J 1/16W
R1540			R92-1824-08	JUMPER R	0	J 1/10W
R1551-553			R92-1823-08	JUMPER R	0	J 1/16W
R1600,601			RK73GB1J682J	CHIP R	6.8K	J 1/16W
R1605,606		*	R92-1949-08	CHIP R	10K	F 1/16W
R1612		*	R92-1950-08	CHIP R	150K	F 1/16W
R1614		*	R92-1947-08	CHIP R	100K	F 1/16W
R1616,617			RK73GB1J103J	CHIP R	10K	J 1/16W
R1618			RK73GB1J153J	CHIP R	15K	J 1/16W
R1620			RK73GB1J153J	CHIP R	15K	J 1/16W
R1621			RK73GB1J682J	CHIP R	6.8K	J 1/16W
R1622,623			RK73GB1J223J	CHIP R	22K	J 1/16W
R1624			RK73GB1J682J	CHIP R	6.8K	J 1/16W
R1701			RK73GB1J393J	CHIP R	39K	J 1/16W
R1702			RK73GB1J303J	CHIP R	30K	J 1/16W
R1703		*	R92-1951-08	CHIP R	1K	F 1/16W
R1704			RK73GB1J332J	CHIP R	3.3K	J 1/16W
R1705			RK73GB1J821J	CHIP R	820	J 1/16W
R1706			RK73GB1J393J	CHIP R	39K	J 1/16W
R1707			RK73GB1J105J	CHIP R	1.0M	J 1/16W
R1708			RK73GB1J102J	CHIP R	1.0K	J 1/16W
R1709			RK73GB1J393J	CHIP R	39K	J 1/16W
R1710			RK73GB1J684J	CHIP R	680K	J 1/16W
R1711			RK73FB2A120J	CHIP R	12	J 1/10W
R1712			RK73GB1J273J	CHIP R	27K	J 1/16W
R1714			RK73FB2A120J	CHIP R	12	J 1/10W
R1716			RK73GB1J104J	CHIP R	100K	J 1/16W
R1801			RK73GB1J271J	CHIP R	270	J 1/16W
R1802		*	R92-1952-08	CHIP R	56K	F 1/16W
R1803		*	R92-1953-08	CHIP R	33K	F 1/16W
R1804			RK73GB1J391J	CHIP R	390	J 1/16W
R1805			RK73GB1J271J	CHIP R	270	J 1/16W
R1806			RK73EB2B1R0J	CHIP R	1	J 1/8W
R1807			RK73GB1J273J	CHIP R	27K	J 1/16W
R1808			RK73GB1J182J	CHIP R	1.8K	J 1/16W
R1809			RK73EB2B1R0J	CHIP R	1	J 1/8W
R1811			RK73EB2B1R0J	CHIP R	1	J 1/8W
R1930			RK73FB2A391J	CHIP R	390	J 1/10W
R1931			RK73FB2A561J	CHIP R	560	J 1/10W

L : Scandinavia K : USA P : Canada R : Mexico C : China I : Malaysia
Y : PX(Far East,Hawaii) T : England E : Europe G : Germany V : China(Shanghai)
Y : AAFES(Europe) X : Australia Q : Russia H : Korea M : Other Areas Δ indicates safety critical components.

PARTS LIST

RXD-M32MD

* New Parts
Parts without **Parts No.** are not supplied.
Les articles non mentionnés dans le **Parts No.** ne sont pas fournis.
Teile ohne **Parts No.** werden nicht geliefert.

21

Ref. No	Add-ress	New Parts	Parts No.	Description	Desti-nation	Re-marks
R1932			RK73FB2A121J	CHIP R 120 J 1/10W		
R1933			RK73FB2A271J	CHIP R 270 J 1/10W		
SW1930		*	S68-0126-08	PUSH SWITCH		
SW1931		*	S68-0127-08	PUSH SWITCH		
SW1932-34		*	S64-0049-08	LEVER SWITCH		
SW1936		*	S64-0050-08	LEVER SWITCH		
D1300			SBE803	DIODE		
D1401			SB00703Q	DIODE		
D1402			1SS355	DIODE		
IC1101			IR3R55	IC		
IC1201			LR376484F	IC		
IC1202			IX2474AF	IC		
IC1300			74ACT02T	IC		
IC1301			FTD2005	IC		
IC1302			CPH5608	IC		
IC1401		*	IX0342AW	IC		
IC1402		*	58X2402T	IC		
IC1601		*	M56788F	IC		
IC1701		*	UDA1347T	IC		
IC1702			NUM431U	IC(REGULATOR)		
IC1801			XC62EP32	IC		
Q1402			UN2113	TRANSISTOR		
Q1403			UN2213	TRANSISTOR		
Q1501			UN2214	TRANSISTOR		
Q1700		*	U2SD601AR	TRANSISTOR		
Q1701			UN2213	TRANSISTOR		
Q1702			2SA1162G	TRANSISTOR		
Q1800			UN2214	TRANSISTOR		
Q1801			2SA1162G	TRANSISTOR		
Q1802			UN2214	TRANSISTOR		
Q1803		*	UN221N	TRANSISTOR		
Q1804		*	2SA1242Y	TRANSISTOR		
Q1805		*	2SA1314C	TRANSISTOR		
Q1806		*	UN221N	TRANSISTOR		
CD MECHANISM (D40-1571-05)						
1	2B		A10-3325-08	CHASSIS		
3	2A		D10-3695-08	SHAFT(TABLE GUIDE)		
5	3A		D10-3696-08	SLED SHAFT		
6	1A		D12-0156-08	CAM		
7	1A		D13-1793-08	GEAR (P)		
8	1A		D13-1794-08	GEAR (C)		
9	1A		D13-1795-08	PULLEY (S)		
10	2A		D13-1796-08	GEAR (A)(S)		
11	3A		D13-1797-08	GEAR (B)(RP)		
12	1A		D16-0713-08	BELT		
13	2A		D23-0328-08	BEARING		
15	2B		E40-8051-08	PIN CONNECTOR (PC BOARD)5P		
20	3A		G01-3969-08	SPRING (S) COMPRESSION		
25	3A		J02-1179-08	PUBBER VIBRATION		
26	3A		J02-1180-08	PUBBER VIBRATION		
27	1A		J19-5768-08	HOLDER (MG)(K) ASSY		
28	2A		J19-5769-08	HOLDER (BU) ASSY		

L : Scandinavia K : USA P : Canada R : Mexico C : China I : Malaysia
Y : PX(Far East,Hawaii) T : England E : Europe G : Germany V : China(Shanghai)
Y : AAFES(Europe) X : Australia Q : Russia H : Korea M : Other Areas Δ indicates safety critical components.

* New Parts
Parts without **Parts No.** are not supplied.
Les articles non mentionnés dans le **Parts No.** ne sont pas fournis.
Teile ohne **Parts No.** werden nicht geliefert.

22

Ref. No	Add-ress	New Parts	Parts No.	Description	Desti-nation	Re-marks
29	2B		J70-0995-08	PC BOARD LOADING		
30	3A		J90-0846-08	RING (LO)(S) CENTER		
31	2A		J99-0592-08	TABLE DISK		
AB	3A		N09-3345-08	SCREW (2.6X16)		
AF	2A		N87-3010-46	SCREW TAPPING (3X10)		
40	2B		S74-0075-08	SWITCH LEAF		
DM	3A		T42-0907-08	MOTOR CHASSIS ASSY(MB)		
FM	3A		T42-0875-08	MOTOR GEAR ASSY(MB)		
LM	2B		T42-0873-08	MOTOR ASSY LOADING		
PU	3B		T25-0061-08	PICKUP ASSY KSS-213C(R)		
MD MECHANISM (D40-1677-05) MDM-99D						
202	2C	*	A10-3517-08	LD BASE LCHSM0089AWZZ		
203	2D	*	A11-1179-08	MD BASE LCHSM0090AWZZ		
204	1C	*	J19-6075-08	CRTRGE HLDR ASSY,LHLDX3007AWM1		
205	1C	*	D10-3941-08	SLIDER LVR ASSY,MLEVF0051AWM1		
207	1C	*	D10-3942-08	HOLDER ARM MLEVF0046AWFW		
208	2C	*	D10-3943-08	SWITCH PLATE MLEVF0047AWFW		
209	2D	*	D10-3944-08	H/A SHIFT ARM MLEVF0048AWFW		
210	1C	*	D10-3945-08	CAM PLATE LEVER,MLEVP0095AWZZ		
212	1C	*	G01-4200-08	LOADING SPRING MSPRD0132AWFJ		
214	3D	*	G02-1703-08	GRIP SPRING MSPRP0030AWFJ		
215	3C	*	G02-1704-08	SHAFT SPRING MSPRP0031AWFJ		
216	1C	*	G01-4201-08	LOADING ARM SP,MSPRT0031AWFJ		
217	2C	*	G01-4202-08	SHIFT ARM SP MSPRT0032AWFJ		
218	1C	*	D13-1992-08	LOADING GEAR(A) NGERH0085AWZZ		
219	1C	*	D13-1993-08	MID GEAR(A) NGERH0086AWZZ		
220	1C	*	D13-1994-08	MID GEAR(B) NGERH0087AWZZ		
221	1C	*	D13-1995-08	MID GEAR(C) NGERH0088AWZZ		
222	2C	*	D13-1996-08	MID GEAR(D) NGERH0089AWZZ		
224	3D	*	D13-1997-08	GRIP RACK NGERR0004AWZZ		
227	3D	*	D19-0322-08	DRIVE SCREW ASSY,NSFT0006AWM1		
228	3D	*	D10-3946-08	PICKUP GUDE SHFT,NSFTM0019AWFW		
230	1D	*	A01-3756-08	SHIELD CVR(TOP),PCOV3029AWFW		
231	2D	*	A01-3757-08	SHIELD CVR(SIDE),PCOV3033AWFW		
232	3D	*	A01-3758-08	SHIELD CVR(BTM),PCOV3031AWFW		
233	1D	*	J02-1478-08	CUSHION PCUSG0045AWZZ		
236	1C	*	G01-4203-08	GND SPRING MSPRT0034AWFJ		
BA		*	N39-1415-45	SCREW(1.4X1.5) LX-BZ0040AWZZ		
BB		*	N38-2020-41	SCREW(2X2) LX-BZ0046AWZZ		
BC		*	N09-3434-08	SCREW(1.4X2.5) LX-BZ0800AFZZ		
BD		*	N39-1750-45	SCREW(1.7X5) LX-BZ0883AFZZ		
BE		*	N09-5197-08	SCREW(1.4X3) LX-JZ0020AWZZ		
BF		*	N09-5198-08	SCREW(1.7X6) LX-JZ0022AWZZ		
BG		*	N39-1445-45	SCREW(1.4X4.5) LX-JZ0024AWZZ		
BH		*	N09-5199-08	SCREW(2X3) XBP3D20P03K00		
BJ		*	N09-5200-08	SCREW(1.7X3) XSPSN17P03K00		
BK			N16-0014-46	WASHER(1.5X3.2X0.5)XWSSD14-05000		
BL			N39-1730-45	SCREW(1.7X3) LX-BZ0846AFZZ		
BM			N39-1450-45	SCREW(1.4X5) LX-JB0025AWZZ		
CN1300		*	E35-2588-08	WIRE HARNESS QCQNW1044AWZZ		
CN1931			E40-8211-08	CABLE CONN(5P) QCNCWXC05AFZZ		
CN1932		*	E40-8617-08	CABLE CONN(6P) QCNCWXC06AFZZ		
CW1501	3D	*	E35-2587-08	FFC(28P) QCQNW1549AWZZ		

L : Scandinavia K : USA P : Canada R : Mexico C : China I : Malaysia
Y : PX(Far East,Hawaii) T : England E : Europe G : Germany V : China(Shanghai)
Y : AAFES(Europe) X : Australia Q : Russia H : Korea M : Other Areas Δ indicates safety critical components.

HOW TO READ THE PARTS LIST

ABBREVIATION OF MODEL AND MASS PRODUCTION'S DESTINATIONS

MODEL	ABB.	Australia	Canada	China	England	Europe	Germany	Korea	Malaysia
RXD-M32MD-L	L	X	-	-	-	-	-	H	-
RXD-M32MD-S	S	-	-	-	T	E	-	H	-
RXD-M32MD-Y	Y	-	-	-	-	-	-	H1	-
RXD-M32MD-LS	LS	X	-	-	-	-	-	H	-

MODEL	ABB.	Mexico	PX/AAFES	Russia	Scandinavia	Shanghai	USA	Other area
RXD-M32MD-L	L	-	-	-	-	-	-	M
RXD-M32MD-S	S	-	-	-	-	-	-	M
RXD-M32MD-Y	Y	-	-	-	-	-	-	M1
RXD-M32MD-LS	LS	-	-	-	-	-	-	M

* New Parts

Parts without **Parts No.** are not supplied.

Les articles non mentionnes dans le **Parts No.** ne sont pas fournis.

Teile ohne **Parts No.** werden nicht geliefert.



Ref. No	Add-ress	New Parts	Parts No.	Description	Desti-nation	Re-marks
CW1502	3D	*	E35-2660-08	FFC(4P)		
CW1931	2C,3C	*	E35-2589-08	FFC(5P)		
CW1932	3C	*	E35-2590-08	FFC(6P)		
M901	3C	*	T42-0974-08	DISC MOTOR		
M902	3C	*	T42-0975-08	FEED MOTOR		
M903	2D	*	T42-0976-08	LOADING MOTOR		
MDPU	2D	*	T25-0099-08	PICKUP		
MDRH	2D	*	T30-0025-08	RECORD HEAD		
PWB-F	2C,3C	*	J70-1414-08	PCB(MECHA)		
SW1930	2C	*	S68-0126-08	PUSH SWITCH		
SW1931	2C	*	S68-0127-08	PUSH SWITCH		
SW1932-34	2C	*	S64-0049-08	PUSH SWITCH		
SW1936	3C	*	S64-0050-08	PUSH SWITCH		

L : Scandinavia
 Y : PX(Far East,Hawaii)
 Y : AAFES(Europe)

K : USA
 T : England
 X : Australia

P : Canada
 E : Europe
 Q : Russia

R : Mexico
 G : Germany
 H : Korea

C : China
 V : China(Shanghai)

I : Malaysia

M : Other Areas indicates safety critical components .

PARTS LIST

RXD-M32MD

RXD-M32MD

SPECIFICATIONS

Main unit

[Amplifier section]

(For U.K. and Europe)

Effective output power during STEREO operation
1 kHz, 10 % T.H.D., at 6 Ω 20 W + 20 W

Rated output power during STEREO operation
1 kHz, 0.7 % T.H.D., at 6 Ω 15 W + 15 W

(For other countries)

Rated output power during STEREO operation
1 kHz, 10 % T.H.D., at 6 Ω 20 W + 20 W

Frequency response
AUX 50 Hz~50 kHz (0 dB ~ -3dB)

[Tuner section]

FM tuner section
Tuning frequency range 87.5 MHz ~ 108 MHz

MW (AM) tuner section

(For U.K. and Europe)

Tuning frequency range 531 kHz ~ 1,602 kHz

(For Australia)

Tuning frequency range 531 kHz ~ 1,602 kHz

(For other countries)

Tuning frequency range
9 kHz step 531 kHz ~ 1,602 kHz
10 kHz step 530 kHz ~ 1,610 kHz

[MD recorder section]

Laser Semiconductor laser
Recording method Field modulation overwrite method
D/A Conversion 1 Bit
Wow & flutter Less than unmeasurable limit

[CD player section]

Laser Semiconductor laser
D/A Conversion 1 Bit
Wow and flutter Less than unmeasurable limit

[Cassette deck section]

Track 4-track, 2-channel stereo
Recording system AC bias system
(Frequency: 65 kHz)

Heads

Playback / recording head 1
Erasing head 1

Motors 1

Wow and flutter 0.2 % (W.R.M.S.)

Fast winding time Approx. 100 seconds
(C-60 tape)

[General]

Power consumption 60 W

Dimensions
W : 180 mm
H : 239 mm
D : 305 mm

Weight (net) 5.7 kg

Speakers

Enclosure Book shelf type, magnetically shielded

Speaker configuration

Woofer 100 mm, cone type

Tweeter 50 mm, cone type

Impedance 6 Ω

Maximum input level 30 W

Dimensions
W : 150 mm
H : 234 mm
D : 197 mm

Weight (net) 2.4 kg(1 piece)



KENWOOD follows a policy of continuous advancements in development. For this reason specifications may be changed without notice.

- Sufficient performance may not be exhibited at extremely cold locations (where water freezes).

Note:

Component and circuit are subject to modification to insure best operation under differing local conditions. This manual is based on Europe (E) standard, and provides information on regional circuit modification through use of alternate schematic diagrams, and information on regional component variations through use of parts list.

KENWOOD CORPORATION

14-6, Dogenzaka 1-chome, Shibuya-ku, Tokyo, 150-8501 Japan

KENWOOD SERVICE CORPORATION

P.O. BOX 22745, 2201 East Dominguez St., Long Beach, CA 90801-5745, U.S.A.

KENWOOD ELECTRONICS CANADA INC.

6070 Kestrel Road, Mississauga, Ontario, Canada L5T 1S8

KENWOOD ELECTRONICS LATIN AMERICA S.A.

P.O. BOX 55-2791, Piso 6 plaza Chase, Cl. 47 y Aquilino de la Guardia Panama, Republic de Panama

KENWOOD ELECTRONICS BRASIL LTDA.

Av. Moema, 170-17, Andar-Cobertura "B", Ed. Maximum Service Center, 04077-020 Moema, São Paulo-SP-Brasil

KENWOOD ELECTRONICS U.K. LIMITED

KENWOOD House, Dwight Road, Watford, Herts., WD1 8EB., United Kingdom

KENWOOD ELECTRONICS BELGIUM N.V.

Meachelsesteenweg 418, B-1930 Zaventem, Belgium

KENWOOD ELECTRONICS DEUTSCHLAND GMBH

Rembrücker Str. 15, 63150 Heusenstamm, Germany

KENWOOD ELECTRONICS FRANCE S.A.

13 Boulevard Ney, 75018 Paris, France

KENWOOD ELECTRONICS ITALIA S.p.A.

Via G. Sirtori, 7/9 20129, Milano, Italy

KENWOOD IBÉRICA S.A.

Bolivia, 239-08020 Barcelona, Spain

KENWOOD ELECTRONICS AUSTRALIA PTY. LTD.

(A.C.N. 001 499 074)
16 Giffnock Avenue, North Ryde, N.S.W. 2113, Australia

KENWOOD ELECTRONICS (HONG KONG) LTD.

Unit 3712-3724, Level 37, Tower 1, Metroplaza, 223 Hing Fong Road, Kwai Fong N.T., Hong Kong

KENWOOD ELECTRONICS GULF FZE

P.O. Box 61318, Jebel Ali, Dubai, U.A.E.

KENWOOD ELECTRONICS SINGAPORE PTE LTD.

No. 1 Genting Lane #02-02, KENWOOD Building, Singapore, 349544

KENWOOD ELECTRONICS (MALAYSIA) SDN BHD.

#4.01 Level 4, Wisma Academy Lot 4A, Jalan 19/1 46300 Petaling Jaya Selangor Darul Ehsan Malaysia

KENWOOD ELECTRONICS (THAILAND) CO., LTD.

2019 New Pechburi Road, Bangkapi, Huaykwang, Bangkok, 10320 Thailand